

1980

Ion chromatography with low-capacity resins and low-conductivity eluents

Douglas Thomas Gjerde
Iowa State University

Follow this and additional works at: <https://lib.dr.iastate.edu/rtd>

 Part of the [Analytical Chemistry Commons](#)

Recommended Citation

Gjerde, Douglas Thomas, "Ion chromatography with low-capacity resins and low-conductivity eluents " (1980). *Retrospective Theses and Dissertations*. 6786.

<https://lib.dr.iastate.edu/rtd/6786>

This Dissertation is brought to you for free and open access by the Iowa State University Capstones, Theses and Dissertations at Iowa State University Digital Repository. It has been accepted for inclusion in Retrospective Theses and Dissertations by an authorized administrator of Iowa State University Digital Repository. For more information, please contact digirep@iastate.edu.

INFORMATION TO USERS

This was produced from a copy of a document sent to us for microfilming. While the most advanced technological means to photograph and reproduce this document have been used, the quality is heavily dependent upon the quality of the material submitted.

The following explanation of techniques is provided to help you understand markings or notations which may appear on this reproduction.

1. The sign or "target" for pages apparently lacking from the document photographed is "Missing Page(s)". If it was possible to obtain the missing page(s) or section, they are spliced into the film along with adjacent pages. This may have necessitated cutting through an image and duplicating adjacent pages to assure you of complete continuity.
2. When an image on the film is obliterated with a round black mark it is an indication that the film inspector noticed either blurred copy because of movement during exposure, or duplicate copy. Unless we meant to delete copyrighted materials that should not have been filmed, you will find a good image of the page in the adjacent frame.
3. When a map, drawing or chart, etc., is part of the material being photographed the photographer has followed a definite method in "sectioning" the material. It is customary to begin filming at the upper left hand corner of a large sheet and to continue from left to right in equal sections with small overlaps. If necessary, sectioning is continued again—beginning below the first row and continuing on until complete.
4. For any illustrations that cannot be reproduced satisfactorily by xerography, photographic prints can be purchased at additional cost and tipped into your xerographic copy. Requests can be made to our Dissertations Customer Services Department.
5. Some pages in any document may have indistinct print. In all cases we have filmed the best available copy.

University
Microfilms
International

300 N. ZEEB ROAD, ANN ARBOR, MI 48106
18 BEDFORD ROW, LONDON WC1R 4EJ, ENGLAND

GJERDE, DOUGLAS THOMAS

ION CHROMATOGRAPHY WITH LOW-CAPACITY RESINS AND LOW-
CONDUCTIVITY ELUENTS

Iowa State University

PH.D.

1980

**University
Microfilms
International**

300 N. Zeeb Road, Ann Arbor, MI 48106

18 Bedford Row, London WC1R 4EJ, England

Ion chromatography
with low-capacity resins
and low-conductivity eluents

by

Douglas Thomas Gjerde

A Dissertation Submitted to the
Graduate Faculty in Partial Fulfillment of the
Requirements for the Degree of
DOCTOR OF PHILOSOPHY

Department: Chemistry
Major: Analytical Chemistry

Approved:

Signature was redacted for privacy.

In Charge of Major Work

Signature was redacted for privacy.

For the Major Department

Signature was redacted for privacy.

For the Graduate College

Iowa State University
Ames, Iowa

1980

TABLE OF CONTENTS

	Page
EXPLANATION OF DISSERTATION FORMAT	1
GENERAL INTRODUCTION	2
SECTION I. EFFECT OF CAPACITY ON THE BEHAVIOR OF ANION-EXCHANGE RESINS	5
INTRODUCTION	6
EXPERIMENTAL	12
RESULTS	15
DISCUSSION	26
REFERENCES	27
SECTION II. CHROMATOGRAPHIC SEPARATION OF METAL IONS ON MACRORETICULAR ANION-EXCHANGE RESINS OF A LOW CAPACITY	29
INTRODUCTION	30
EXPERIMENTAL	32
RESULTS	36
CONCLUSIONS	49
REFERENCES	50
SECTION III. ANION CHROMATOGRAPHY WITH LOW-CONDUCTIVITY ELUENTS I	51
INTRODUCTION	52
EXPERIMENTAL	54

	Page
RESULTS	59
DISCUSSION	76
CONCLUSIONS	80
REFERENCES	81
SECTION IV. ANION CHROMATOGRAPHY WITH LOW-CONDUCTIVITY ELUENTS II	82
INTRODUCTION	83
EXPERIMENTAL	84
RESULTS	87
DISCUSSION	108
REFERENCES	110
SECTION V. EFFECT OF CAPACITY ON THE BEHAVIOR OF LOW-CAPACITY MACRORETICULAR ANION-EXCHANGE RESINS	111
INTRODUCTION	112
EXPERIMENTAL	114
RESULTS AND DISCUSSION	116
CONCLUSIONS	125
REFERENCES	126
SECTION VI. CATION CHROMATOGRAPHY USING A CONDUCTIVITY DETECTOR	127
INTRODUCTION	128
EXPERIMENTAL	130
RESULTS AND DISCUSSION	133

	Page
CONCLUSIONS	154
REFERENCES	155
GENERAL CONCLUSIONS	156
FUTURE WORK	157
GENERAL REFERENCES	162
ACKNOWLEDGMENTS	163

EXPLANATION OF DISSERTATION FORMAT

The dissertation is divided into six sections. Sections II through VI represent papers in their final publication forms. The introduction in Section I is expanded to familiarize the reader with basic ion-exchange theory. Parts of several of the introductions are redundant because each section is complete by itself. Reference to tables, figures and literature apply only to those references contained within that section. The literature cited in the General Introduction and Future Work is listed in the General References list at the end of the dissertation.

All of the work presented here was done under the direction and guidance of Dr. J. S. Fritz. Dr. G. Schmuckler, a visiting professor on sabbatical from the Israel Institute of Technology, extended advice and guidance for work shown in Sections III and IV. Ms. Rose Becker, a summer student, initiated work shown in Section VI under the direction of the author.

GENERAL INTRODUCTION

Most ion-exchangers marketed today are resins that have been functionalized to the highest possible capacity. The capacities of these ion exchangers vary from batch to batch because of the difficulties in duplicating reaction conditions. Furthermore, different polymer substrates will produce ion exchangers of different capacities because the number of sites available for functionalization changes. For example, a highly crosslinked resin will probably have a lower capacity than a lightly crosslinked resin. Work by Fritz and Story (1,2) shows that ion-exchange capacity dramatically affects the behavior of sulfonated cation-exchangers. Distribution ratios of cations decrease with decreasing capacity. Selectivity coefficients also vary, but not in such a predictable manner. The lower capacity resins were found to be useful for many separations because lower eluent concentrations could be used.

The work presented in Sections I and II in this dissertation is an extension of the work by Fritz and Story. Strong-base anion exchangers with capacities ranging from 0.04 to 1.46 mequiv./g were prepared and characterized. Distribution ratios also decrease for anions when anion-exchange resin capacity is decreased but selectivity coefficients are essentially constant for the anions studied.

Several applications of low-capacity anion-exchange resins are shown in Sections I and II. One of the more interesting applications of low-capacity resins is the use of XAD-1 0.04 mequiv./g resin in the separator column of an ion chromatograph. Ion chromatography developed by Small et al. (3) is a significant improvement in the analysis of anions. The system consists of a separator column made with a low-capacity anion-exchanger, followed by a suppressor column of high-capacity cation-exchanger in the hydrogen form. The effluent from the suppressor column is directed into a conductivity cell. The low-capacity separator column needs only a dilute eluent solution ($\sim 0.006M$) of sodium carbonate and sodium bicarbonate to separate sample anions. The suppressor column allows the use of a conductivity detector by converting the sodium carbonate and sodium bicarbonate into a weakly conducting solution of carbonic acid and the sample salts of chloride, sulfate and other anions into highly conducting acids.

Ion chromatography is a sensitive and useful problem solving technique but it suffers from the need for frequent regeneration of the suppressor column. In the summer of 1978, Dr. Gabriella Schmuckler, on sabbatical from Technion, Haifa, Israel, proposed a system in which a conductivity detector is connected directly to a separator

column. Using the ion-exchange expertise already known, a working system called anion chromatography was quickly discovered. The separating resin and eluent are carefully chosen so that the eluent inherently has a low background conductivity. Anion chromatography is described in Sections III and IV. Selectivity data for the low-capacity resins used in anion chromatography is presented in Section V.

It seemed possible to develop an analogous method for cations. Finding an eluent of a low enough background conductivity proved to be a difficult problem. Cation chromatography was finally developed by using eluents that have a relatively high background conductance such as nitric acid. Sample cations appear as negative peaks beneath the background signal. Cation chromatography is described in Section VI.

SECTION I.
EFFECT OF CAPACITY ON THE BEHAVIOR
OF ANION-EXCHANGE RESINS

INTRODUCTION

It would be useful to be able to predict the effect of resin capacity on the behavior of ion-exchange resins, if capacity is to be used as a variable in ion-exchange chromatography. However, the prediction of selectivity coefficients or the relative affinities of ions for an ion-exchanger has proved to be a difficult problem.

Gregor (1,2) first put forth a semimechanistic theory in which selectivity is considered to arise primarily because of differences in the hydrated volumes of counterions in the exchanger. Eq. 1 shows how selectivity may be predicted:

$$RT \ln K_A^{B'} = \pi (V_A - V_B) \quad (1)$$

$K_A^{B'}$ is the selectivity coefficient corrected for ion activities of ion B over ion A for the exchanger, V_A and V_B are hydrated volumes of the counterions in the resin phase, π is the "elastic" counterpressure exerted by the exchanger, T is temperature and R is a constant. Solvent molecules are absorbed in the ion exchanger and swell the resin. The exchanger crosslinking prevents the polymer from being completely dissolved and exerts a counterpressure that increases with increasing crosslinking.

Although Gregor's theory is simple, it does predict and explain several of the phenomena associated with cation exchange: ions with smaller hydrated volumes have a greater affinity for an ion exchanger than ions with larger hydrated volumes. This fits the normal affinity sequence cesium > potassium > sodium > lithium for a sulfonated resin. It has been shown (3) that as a sulfonated ion-exchange resin is converted from a large hydrated ion to a smaller ion, the selectivity coefficient of the resin for the smaller ion over the larger ion decreases. This is also predicted by Eq. 1 because when a resin is in the smaller hydrated ion form the counterpressure, π , is lower.

Many authors (4-9) have made use of Gregor's theory in their work; however, the facts that affinity reversals are not explained and that the model completely fails for anion exchange, show this theory is not completely true.

Eisenman (10,11) and Ling (12,13) take a more thermodynamic approach and argue that the energy of hydration of counterions in solution and electrostatic interactions of the ion pair in the exchanger are the dominant factors for predicting ion-exchange selectivity. Eisenman describes the theory by Eq. 2:

$$-RT \ln \bar{x}_A^B = \frac{e^2}{r_Y + r_A} - \frac{e^2}{r_Y + r_B} - (\Delta G_A - \Delta G_B) \quad (2)$$

where e is the electronic charge (expressed in suitable units), r_X is the radius of the ion-exchange functional group and r_A and r_B are the radii of the counter ions A and B respectively. ΔG is the free energy of the removal of water molecules from the counter ions. According to Eq. 2, ion B will have a greater affinity than ion A for an ion exchanger when the hydrated B ion's radius is smaller than the hydrated A ion's radius and when the energy gain of the ion pair formation of ion B with the exchanger is greater than that with ion A. In the case where r_X is relatively large, the term $[e^2/(r_X + r_A) - e^2/(r_X + r_B)]$ will be insignificant, and selectivity will be determined by the value of $(\Delta G_A - \Delta G_B)$. A sulfonate group is considered large and the normal sulfonated exchanger affinity sequence, cesium > potassium > sodium > lithium, is effectively predicted. If r_X is smaller, as it is in the case of carboxylate groups, the term $[e^2/(r_X + r_A) - e^2/(r_X + r_B)]$ will be more significant, and the exchanger will now give preference to the ions of smaller radii. The reversed affinity sequence, lithium > sodium > potassium > cesium, is found with carboxylate resins.

Ling's basic assumptions are similar to Eisenman's but his approach is more detailed. Chu et al. (14) took a simpler approach and argued that the hydration energy of counter ions in solution is the dominant factor. Data

accumulated by Reichenberg (3) show these theories are more effective than Gregor's theory in predicting selectivity reversals of cation exchange and affinity sequences of anions and cations for ion exchangers.

None of the theories discussed here or other theories that have been proposed (15,16) imply that ion-exchange capacity has any effect on the selectivity of ions for a resin.

The structure of an ion exchanger should be considered when determining the effect of resin capacity on ion-exchange behavior. There are nineteen positional isomers of functional groups in a bead made up of poly (styrene, ethylstyrene and divinylbenzene) (17). A macroporous resin has a high surface area, and the ion-exchange groups are likely to be on the surface, (i.e., in direct contact with a mobile phase) as well as within the resin matrix. The reported selectivity coefficient of one ion over another, then, is the composite of 38 individual selectivity coefficients. When ion-exchange capacity is used as a variable, it is probable that the relative contributions of these selectivity coefficients to the composite selectivity coefficient will change with resin capacity because the relative amounts of types of functional groups will change with capacity. For example, a low-capacity resin is likely to have a larger portion of its functional

groups on the surface of the resin bead than a resin of high capacity because surface sites react faster than other sites. Another effect of structure is that resins of increasing capacity have functional groups that are closer together. As functional groups become closer together, the possibility of interaction between them becomes greater.

Although porous silica beads coated with an ion-exchange material have been used for separation of ionic organic compounds, most of the work on inorganic ion-exchange chromatography has been carried out with commercially available resins of high capacity. It is remarkable that so little attention has been paid to ion-exchange resins of lower capacity. Only a few reports have appeared which describe or attempt to predict the effect of varying the capacity of a resin (18-20). These studies were all done with sulfonated cation exchangers. Small et al. (21) made practical use of a proprietary anion-exchange resin of low capacity for chromatographic separation of inorganic anions.

This section describes the preparation and properties of a series of macroporous anion-exchange resins of varying capacity. The results show that anion-exchange resin capacity can easily be varied and that resin capacity is a

useful parameter to be considered for practical chromatographic separations.

EXPERIMENTAL

Resin synthesis

The materials used for the synthesis of the anion-exchange resins were macroporous poly (styrene-divinylbenzene) copolymers, XAD-1, 2 and 4, obtained from the Rohm and Haas Co. Batches of the resin beads were ground in a Model 4-E Quaker City Mill. The 80-100 mesh particles were removed by dry sieving and retained for synthesis of the anion-exchange resins. After washing with methanol and water, the resin was slurried with methanol, allowed to settle and the unsettled fines were decanted.

The air-dried resin was chloromethylated using a procedure described by Goldstein and Schmuckler (22). A 3 g portion of the resin was swollen with 10 mL of chloromethylmethylether. With stirring, 11 mL of methylene chloride, 3 mL of nitromethane and 3 g of zinc chloride were added. The capacities of the anion-exchange resins were controlled by varying the time of chloromethylation, from 5 minutes to 6 hours. All reactions were performed at room temperature except for the highest capacity resin in each XAD series, where the reaction was 6 hours at 45-50°C. After the appropriate time, the reactions were quenched by adding water. The resins were filtered, washed with water and methanol and air dried. The resins were

then aminated by adding liquified trimethylamine and allowing the amine to evaporate overnight. The final product was washed with 1 M hydrochloric acid, 2-propanol and water, and dried overnight at 60°C.

Capacity measurements

Approximately 0.5 g of dry resin was accurately weighed and transferred quantitatively to a small column. The resin was converted to the hydroxide form with approximately 30 bed volumes of 1 M sodium hydroxide and washed with water. Then 1 M sodium chloride was added and the sodium hydroxide in the effluent was titrated with standard hydrochloric acid.

Distribution ratios

Distribution ratios of anions as a function of resin capacity were calculated from retention times measured on a column of the resin. A Dionex System Ten Ion Chromatograph was used to measure the retention volumes. Pumping was at 30%, which provided an eluent flow of 2.50 mL/min. The sample loop volume was 100 μ L. An 80 mm x 2 mm i.d. column was used for all experiments so that the mobile phase volume and the amount of solid phase would remain constant. A solution of sodium carbonate and sodium bicarbonate in water was used as the eluent. The mobile phase volume was measured by injecting water and noting the volume to the

negative water peak.

Selectivity coefficients

Selectivity coefficients of different anions were measured relative to chloride. The resin was converted to the anion form, air dried, and a weighed amount was shaken for at least 2 hours with a measured volume of solution containing known concentrations of the anion and chloride. After equilibration, the chloride remaining in solution was determined by titration with mercuric nitrate. Selectivity coefficients were calculated by assuming that all chloride gone from solution replaced a counter ion on the resin. The ratio of resin counter ion to chloride was high in order to provide a low and fairly consistent conversion of the resin to the chloride form.

RESULTS

Resins prepared

Rohm and Haas XAD-1, -2 and -4 are poly (styrene-divinylbenzene) resins of excellent physical strength and stable pore structure; they vary in surface area and average pore size (Table I). These resins have found extensive use for sorption of organic impurities from water and for chromatographic use but have not been previously used as a starting material for preparation of anion-exchange resins. The anion-exchange resins used in the present work were made by chloromethylation of XAD resins under mild conditions, followed by amination with trimethylamine to produce a quaternary ammonium functional group. The capacities of the resins were varied by controlling the time of the chloromethylation reaction (See Experimental for conditions). Table I lists the capacities and chloromethylation times for the anion-exchange resins that were prepared. It was possible to prepare resins of a greater capacity range from XAD-1 as the starting material.

Distribution ratios as a function of resin capacity

Distribution ratios of various anions were measured by a column procedure in which a solution of the anion to be tested was injected onto a column of the XAD

Table I. Properties of the resins prepared

Resin	Surface Area (m ² /g)	Av. Pore Diam. (Å)	Time of Chloromethylation (min)	Capacities (mequiv./g)
XAD-1	100	205	---	0.17
			20	0.35
			30	0.41
			90	0.71
			210	0.92
			270	1.01
			300 ^a	1.46
XAD-2	300	90	15	0.22
			60	0.31
			90	0.48
			120	0.59
			300 ^a	0.65
XAD-4	784	50	5	0.13
			10	0.26
			30	0.51
			90	0.63
			300 ^a	0.76

^aReaction temperature was 45-50°C. All other reactions were at room temperature.

anion exchanger that had been conditioned with a sodium carbonate and sodium bicarbonate eluent. The anion was eluted from the column with the same eluent and the retention volume of the anion measured. The mass distribution ratio was then calculated using the equation,

$$V_R = V_M(D_m + 1) \quad (1)$$

where V_R is the retention volume, V_M is the holdup volume between the points of injection and detection and D_m is the mass distribution ratio.

Figures 1 and 2 show distribution ratios for several anions as a function of resin capacity. Because a mixture of two anions had to be used in the eluent, it is not possible to calculate any meaningful selectivity coefficients. However, the results do show that in each case the distribution ratio of the anion increases with increasing capacity. The practical significance is that a much more dilute eluent can be used in column chromatography with a resin of very low exchange capacity.

There is no great difference in resins prepared from XAD-1, -2 or -4. However, the figures show that with XAD-1 resin there is a leveling off of the slope at higher capacity, and in some cases the slope of the plot becomes slightly negative. The selectivity of acetate > iodate is the reverse of the reported selectivity with the gel-type

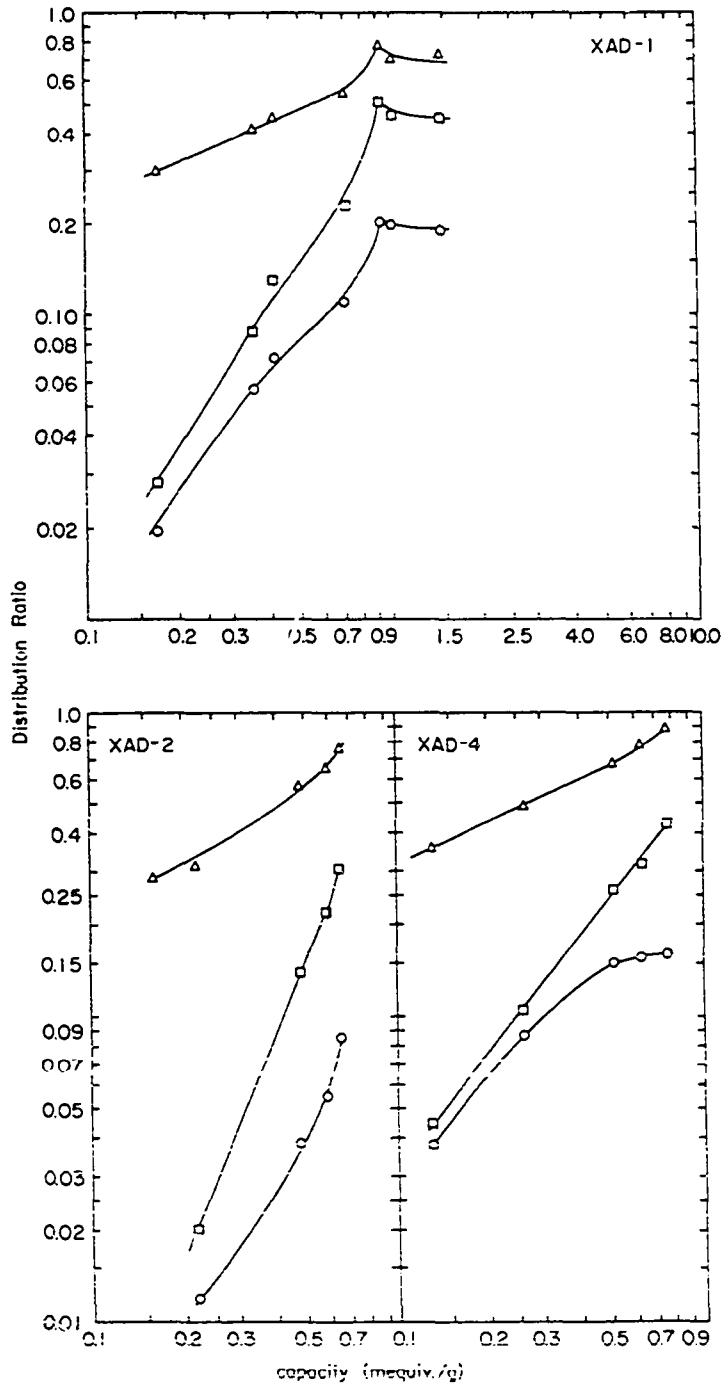

Figure 1. Distribution ratios of anions for resins of different capacity; Eluent: 4×10^{-4} M sodium bicarbonate and 3×10^{-3} M sodium carbonate
 Δ, acetate; □, iodate; O, fluoride

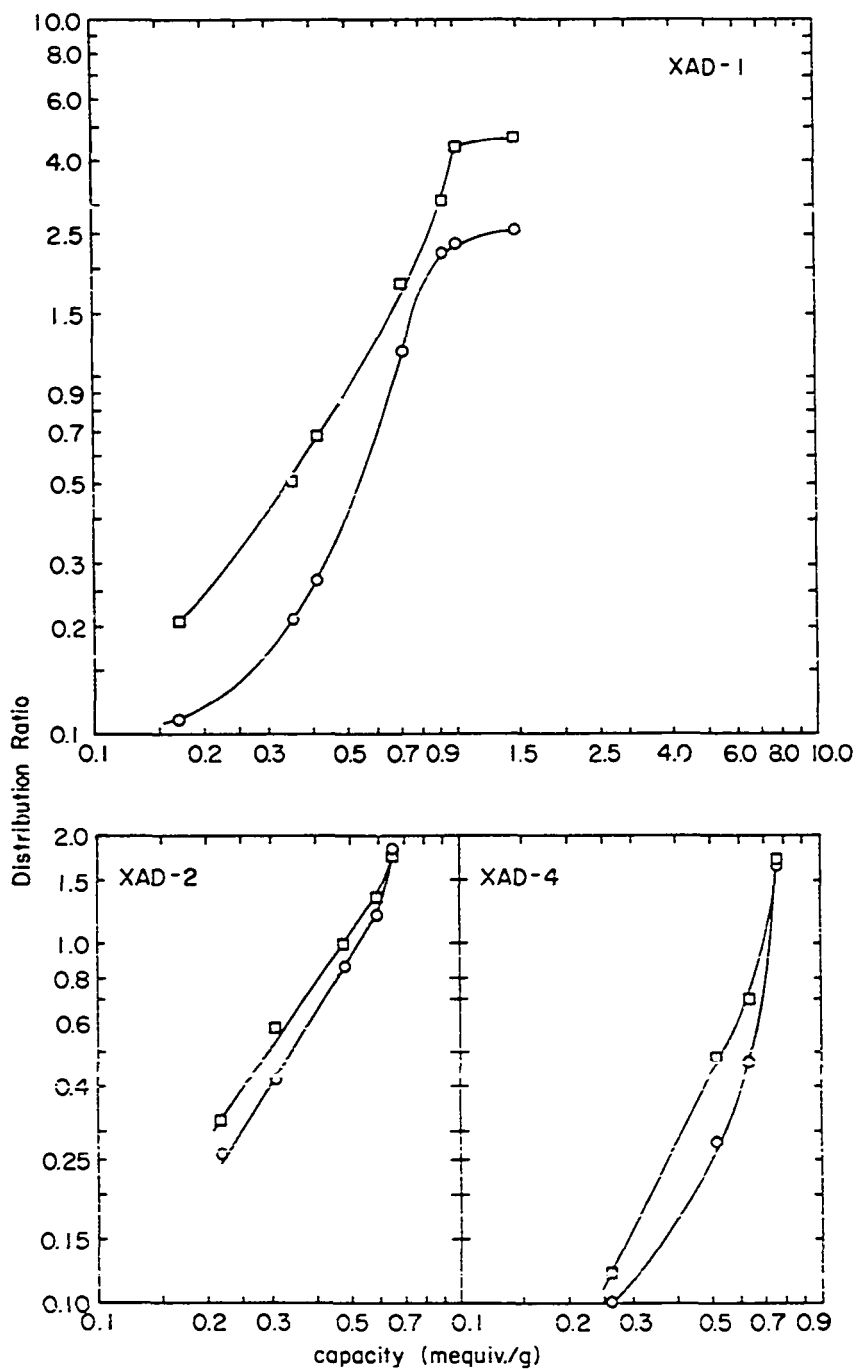

Figure 2. Distribution ratios of anions for resins of different capacity; Eluent: 1.2×10^{-2} M sodium bicarbonate and 1×10^{-2} M sodium carbonate; □, sulfate; ○, chloride

resin Dowex 1 X8. This may be caused by a greater interaction of acetate with the XAD resin matrix, where the ionic functional groups are less concentrated than on the gel resin.

Selectivity coefficients as a function of resin capacity

Selectivity coefficients of nitrate, hydroxide and fluoride relative to the chloride ion were measured for XAD-1 anion-exchange resins of different capacities. A weighed amount of resin in the anion form to be exchanged with chloride was equilibrated with a solution containing known concentrations of that anion and chloride. After equilibration, the chloride in the aqueous phase was determined by titration. The concentration of the other anion in solution and the mole fraction of each anion in the resin phase could then be deduced and the selectivity coefficient calculated.

The exchange reaction (using nitrate as an example) and the selectivity coefficient expression are:

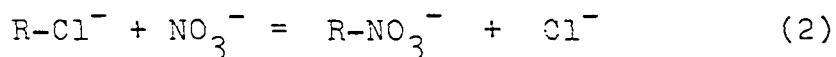

$$K_{\text{Cl}^-}^{\text{NO}_3^-} = \frac{[\text{R-NO}_3^-] [\text{Cl}^-]}{[\text{R-Cl}^-] [\text{NO}_3^-]} \quad (3)$$

The selectivity coefficients given in Table II indicate that within a reasonable experimental error the constants do not vary with resin capacity.

The constancy of selectivity coefficient with resin capacity has useful implications for column chromatography. Suppose that nitrate is injected onto a chloride-form anion-exchange column and that a chloride solution will be used to elute the nitrate. In column chromatography the sample normally uses 1% or less of the resin capacity; therefore $[R-Cl^-]$ is essentially constant and equal to the resin capacity. The ratio of $[R-NO_3^-]$ to $[NO_3^-]$ is a nitrate distribution ratio, D , which can be related to the retention volume for elution of nitrate from the column. The term $[Cl^-]$ will be approximately equal to the eluent chloride concentration, $[Eluent]$. Substituting these into Eq. 3:

$$K \frac{NO_3^-}{Cl^-} = D \frac{[Eluent]}{Capacity} \quad (4)$$

Using this equation, the eluent concentration necessary to obtain any desired value of D can be estimated for a resin of known capacity. It will also be seen that using a resin of lower capacity will reduce the eluent concentration.

Table II. Selectivity coefficients for XAD-1 anion-exchange resins of different capacity

Capacity XAD-1 mequiv./g	Mole fraction chloride form	$K_{\text{Cl}^-}^{\text{NO}_3^-}$
0.17	0.04	5.0
0.41	0.06	3.2
0.71	0.05	3.7
0.92	0.05	3.7
1.01	0.05	3.6
1.46	0.04	4.0

Capacity XAD-1 mequiv./g	Mole fraction chloride form	$K_{\text{Cl}^-}^{\text{OH}^-}$
0.17	0.15	0.10
0.41	0.13	0.11
0.71	0.11	0.10
0.92	0.09	0.11
1.01	0.09	0.11
1.46	0.08	0.13

Table II. (Continued)

Capacity XAD-1 mequiv./g	Mole fraction chloride form	$K \frac{F^-}{Cl^-}$
0.17	0.22	0.08
0.41	0.23	0.05
0.71	0.20	0.04
0.92	0.16	0.05
1.01	0.17	0.04
1.46	0.12	0.05

Chromatographic separations with low-capacity resins

To demonstrate the applicability of the new resins, a 50 cm x 3 mm i.d. glass column was packed with 150-160 mesh XAD-1 anion-exchange resin, 0.04 mequiv./g capacity, and the column was connected to a Dionex Corp. "Ion Chromatograph". Figure 3 shows the chromatogram for separation of a sample containing five different anions. The resolution of the sample components is comparable to that obtained using the proprietary commercial resin. The back pressure of the XAD-1 column is quite low (~ 100 psi), suggesting the feasibility of using XAD-1 anion resin of a smaller particle size to obtain still better separations.

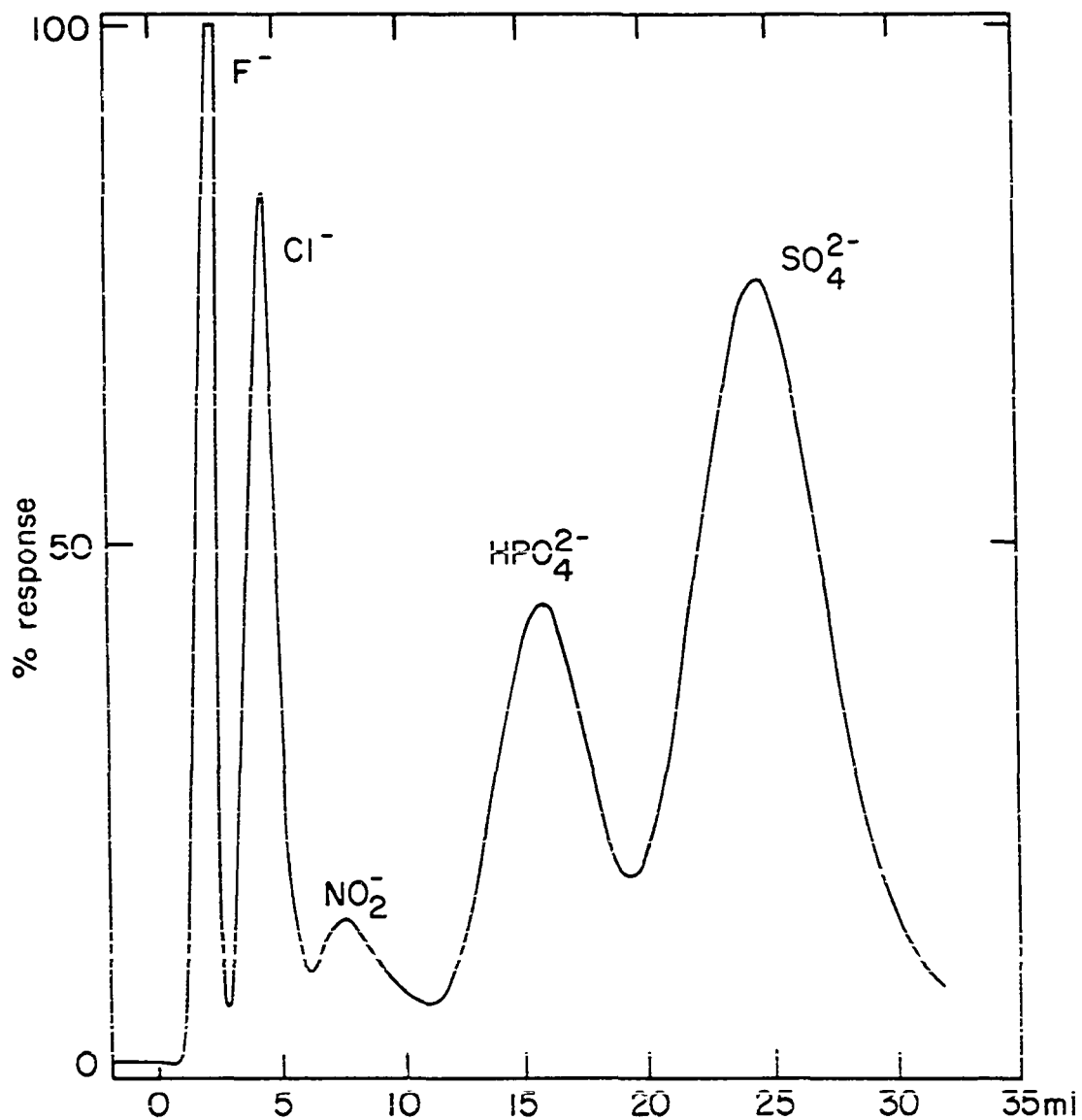

Figure 3. Separation of fluoride, chloride, nitrite, phosphate and sulfate respectively on low-capacity XAD-1 anion-exchange resin; Resin: 0.04 mequiv./g, 150-160 mesh XAD-1; Column: 50 cm x 3 mm i.d.; Eluent: 2.50 ± 0.05 mL/min, 0.0015 M $NaHCO_3$ and 0.0012 M Na_2CO_3

DISCUSSION

The three anion-exchange resins act similarly. However, a striking difference between them is that the same reaction conditions produce approximately twice the capacity when XAD-1 is used as the starting material, rather than XAD-2 or XAD-4. The XAD-1 has lower surface area but larger pores than the others.

The leveling off of XAD-1 distribution ratios at higher capacities may be due to the more efficient retention of carbonate by the resin. At the higher capacities the resin functional groups are closer together and the carbonate can more easily combine with two resin functional groups.

Perhaps the most significant accomplishment of this work has been to demonstrate the effect of capacity on the eluent concentration needed to elute anions in column chromatography. A resin of lower capacity permits the use of a lower eluent concentration. The capacity of XAD anion-exchange resins can be easily varied, making this a parameter that can be changed to permit elution of anions that normally are held tightly by a resin.

REFERENCES

1. Gregor, H. P. J. Am. Chem. Soc. 1948, 70, 1293.
2. Gregor, H. P. J. Am. Chem. Soc. 1950, 73, 642.
3. Reichenberg, D. in "Ion Exchange"; Marinsky, J. A., Ed.; Marcel Dekker: New York, 1966; Vol. 1, Chapter 7.
4. Glueckauf, E. Proc. Roy. Soc. (London) 1952, A214, 207.
5. Davies, C. W.; Yeoman, G. D. Trans. Faraday Soc. 1953, 49, 968.
6. Soldano, B. A.; Larson, Q. V. J. Am. Chem. Soc. 1955, 77, 1331.
7. Soldano, B. A.; Chesnut, D. J. Am. Chem. Soc. 1955, 77, 1334.
8. Soldano, B. A.; Larson, Q. V.; Meyers, G. E. J. Am. Chem. Soc. 1955, 77, 1339.
9. Boyd, G. E.; Lindenbaum, S.; Meyers, G. E. J. Phys. Chem. 1961, 65, 577.
10. Eisenman, G. in "Membrane Transport and Metabolism"; Kleinzeller, A; Kotyk, A., Eds.; Academic Press: New York, 1961; pp. 163-179.
11. Eisenman, G. Biophys. J. Suppl. 1962, 2(2), 259.
12. Ling, G. N. "A Physical Theory of the Living State"; Blaisdell: New York, 1962; Chapter 4.
13. Ling, G. N. J. Gen. Physiol. Suppl. 1960, 43(5), 149.
14. Chu, B.; Whitney, D. C.; Diamond, R. M. J. Inorg. Nucl. Chem. 1962, 24, 1405.
15. Harris, F. E.; Rice, S. A. J. Chem. Phys. 1956, 24, 1258.
16. Pauley, J. L. J. Am. Chem. Soc. 1954, 76, 1422.
17. Rieman, W.; Walton, H. F. "Ion Exchange in Analytical Chemistry"; Pergamon Press: New York, 1962; p. 13.

18. Boyd, G. E.; Soldano, B. A.; Bonner, O. D. J. Phys. Chem. 1954, 58, 456.
19. Fritz, J. S.; Story, J. N. J. Chromatogr. 1974, 90, 267.
20. Fritz, J. S.; Story, J. N. Anal. Chem. 1974, 46, 825.
21. Small, H.; Stevens, T. S.; Bauman, W. C. Anal. Chem. 1975, 47, 1801.
22. Goldstein, S.; Schmuckler, G. Ion Exchange and Membranes 1973, 1, 135.

SECTION II.

CHROMATOGRAPHIC SEPARATION OF METAL IONS
ON MACRORETICULAR ANION-EXCHANGE RESINS
OF A LOW CAPACITY

INTRODUCTION

The separation of metals in the form of chloro complexes from aqueous hydrochloric acid solutions using anion exchange columns is a well established analytical technique (1-7). Hydrochloric acid has been a useful medium because it can be used to dissolve a large number of metals. Equally important, it is a useful reagent for the quantitative spectrophotometric determination (8) of many metals that may be automated with the use of a flow cell (9,10). The very strong sorption of chloro complexes of several metal ions on conventional anion-exchange resins makes it difficult or impossible to elute these metal ions. In some cases elution has been accomplished by mixing perchloric acid with the hydrochloric acid eluent (10).

Recently it was shown that the distribution coefficients of simple inorganic anions decrease with decreasing capacity of the anion-exchange resin (11). Fritz and Story have reported a similar effect for cations on cation-exchange resins of lower capacity (12,13). In the present investigation, a series of macroporous anion-exchange resins of very low capacity was prepared and the exchange behavior of anionic metal chloride complexes studied. Distribution coefficients on the new anion-exchange resins are significantly lower, and many analytical separations of metal ions

have been obtained that would be impossible to achieve on conventional resins of high capacity.

EXPERIMENTAL

Apparatus

Most of the work was done with a liquid chromatograph that has been described previously (14). The system employs automatic detection with a Tracor 970 variable-wave-length detector. All detection was done at 225 nm unless otherwise stated. Various concentrations of hydrochloric acid were used as the dye. Flow rates of the eluent and dye were 1.5 mL/min. Sample loop size was 200 μ L. An 80 mm x 2 mm i. d. column was used for the platinum - gold and palladium - gold separations. For the bismuth - mercury and for the tin separations a 25 mm x 2 mm column with 20 mm x 2 mm ends was used. Both columns used Altex 200 - 28 glass connectors.

The copper, palladium and platinum separation required a longer column. The resulting higher back pressure made the liquid chromatograph described above unsuitable. The chromatograph used for this separation is outlined in Fig. 1. This chromatograph was designed to allow only glass, Teflon, Kel-F or Tefzel plastic to come into contact with the mobile phase.

The eluent tank was a 500 mL glass reagent bottle. The mobile phase was pumped from the eluent tank by a CMP-2 "Cheminert" metering pump. The pump is rated 0 - 500 psi.

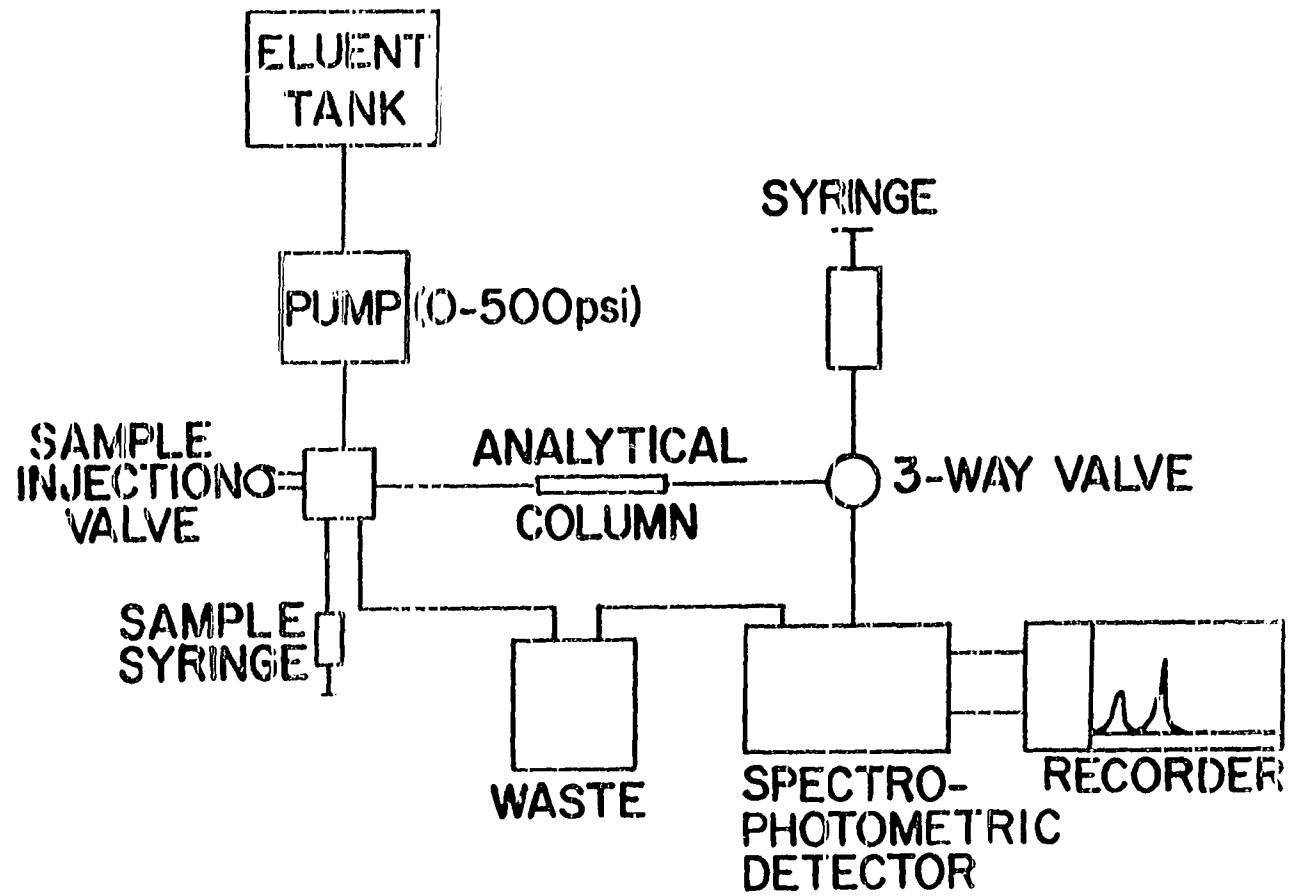

Figure 1. Schematic diagram of the liquid chromatograph

It employs a three piston design to reduce pressure and flow pulsation. The pump can be adjusted to flow rates of 2.4 to 120 mL/hr. All experiments were done at a flow rate of 60 mL/hr. Flow control is provided by pneumatically actuated 3-way valves which control the filling and draining of each piston. The sample injection system is a 3-way and 4-way valve modeled after an Altex 201-56 sample injection valve. All work was performed using a 56.3 μ L sample loop. The 3-way valve between the column and detector allowed the removal of bubbles in the flow cell by rapidly forcing water through the system with a syringe. Two 500 mm x 2 mm glass columns were connected in series. The columns were individually slurry packed with a syringe. The resin was 150-160 mesh XAD-1, 0.04 mequiv./g, strongly basic anion-exchange resin. The detector used was the same as for the other separations.

Measurement of distribution coefficients

Approximately 0.15 g of dried resin was accurately weighed into a 50 mL glass stoppered flask. The metal salt-hydrochloric acid solution was pipetted into the flask and the mixture was left for 6 to 12 hours, with occasional shaking. Generally 15 mL of solution were used; however, smaller and larger amounts of solution were used for extremely small and large distribution coefficients.

The resin was filtered off and metal content of the solution was determined by the absorbance at an appropriate wavelength. Distribution coefficients, D, were calculated by assuming that all the metal removed from the solution had been sorbed on on the resin where D is defined as

$$D = \frac{\text{amount of metal/g of dry resin}}{\text{amount of metal/mL of solution}}$$

Reagents

The copolymer material used for the synthesis of low capacity anion exchange resins was macroreticular poly (styrene-divinylbenzene) beads. XAD-1 and XAD-4 were obtained from Rohm and Haas Co. The synthesis has been described in another paper (11). The beads are highly crosslinked and have excellent chemical and mechanical stability.

Reagent grade metal chlorides were used when available. The stock silver solution was made from silver perchlorate. Platinic chloride solutions were made by diluting a 10% stock solution with the appropriate concentration of hydrochloric acid. The stock solution was obtained from Fisher Scientific Co.

RESULTS

The distribution coefficients for several metal ions were determined as a function of aqueous hydrochloric acid concentration for low capacity anion-exchange resins. The metal ions chosen for study form chloro complexes that are tenaciously held by conventional anion-exchange resins. The results in Figure 2 show distribution coefficients that are significantly lower for the new resins than for conventional anion-exchange resins of high capacity. Furthermore, the distribution coefficients tend to decrease more rapidly at the very low capacities, as shown by the behavior of platinum(IV) in Figure 2.

The distribution coefficients in Figure 2 suggest that by suitable selection of hydrochloric acid concentration, column separations of some of the metal ions in Figure 2 from other metals and from each other should be possible. Several actual separations are reported below using the chromatographic and detection system outlined in the Experimental Section.

*

Separation of platinum(IV) or palladium(II), gold(III) and base metals

A separation of chromium(III), platinum(IV) and gold (III) on 0.21 mequiv./g XAD-4 is shown in Figure 3. The sample is dissolved in approximately 0.2 M hydrochloric acid and injected on the column with eluent 0.2 M

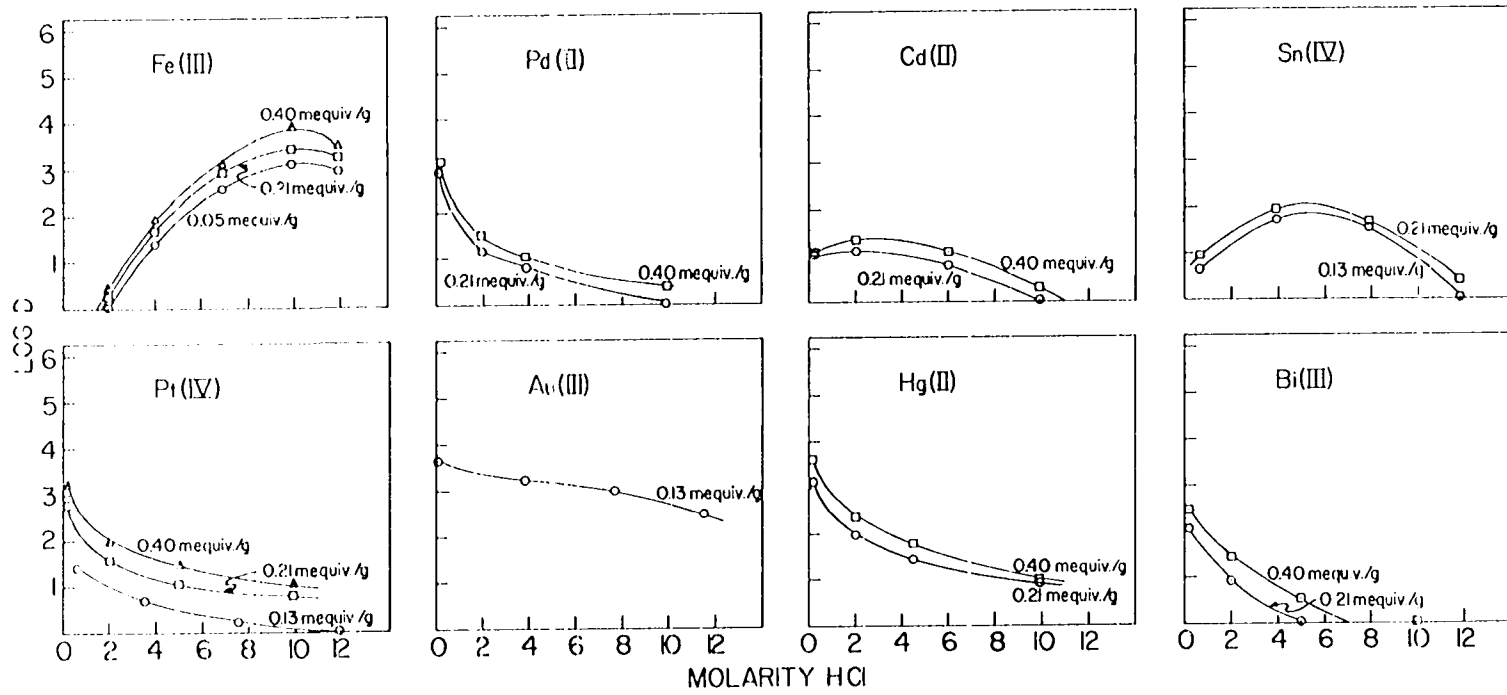

Figure 2. XAD-4 anion exchange distribution coefficients (D) of various metals as a function of hydrochloric acid concentration and capacity

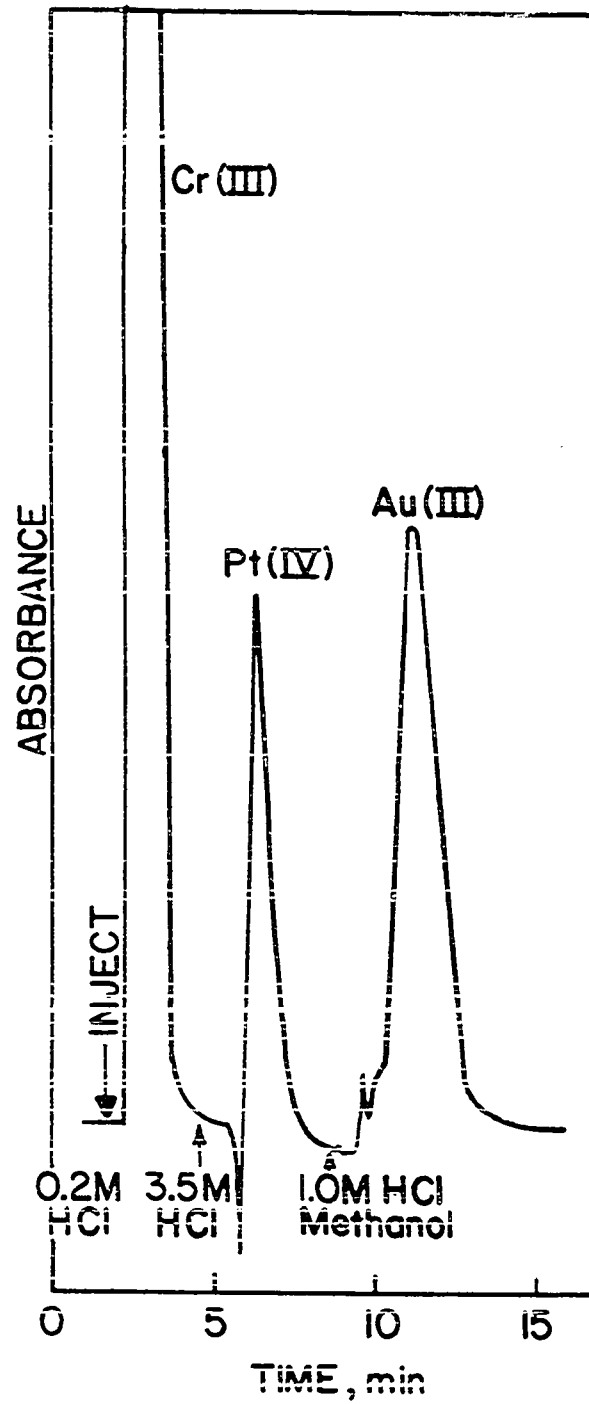

Figure 3. Separation of 2.0 mg chromium(III), 39 μg platinum(IV) and 7.8 μg gold(III)

hydrochloric acid. Chromium(III) and other base metals are eluted under these conditions. Platinum(IV) is removed with 3.5 M hydrochloric acid. Gold(III) is eluted with 1.0 M hydrochloric acid in methanol. A separation of copper(II), palladium(II) and gold(III) on 0.21 mequiv./g XAD-4 is shown in Figure 4. The same procedure is used to carry out the separation.

The negative peak directly preceding platinum(IV) in Figure 3 is a solvent change peak and is typical in a step-gradient elution from a low concentration to a high concentration of hydrochloric acid. The small peak right ahead of the gold(III) peak is also a solvent change peak. None of the solvent change peaks interfered with the peak heights of the metals analyzed. Standard solutions of platinum, palladium and gold of various concentrations gave linear calibration curves of peak height vs. μg of metal ion.

Tables I and II show there is little or no interference with the foreign metals tested.

Separation of bismuth(III) and mercury(II) from other metals

Bismuth(III) and mercury(II) also form stable anion complexes but are somewhat difficult to elute with aqueous hydrochloric acid from ordinary anion-exchange resins. In the chromatogram shown in Figure 5 bismuth(III) and mercury(II) are separated from each other and iron(III) on

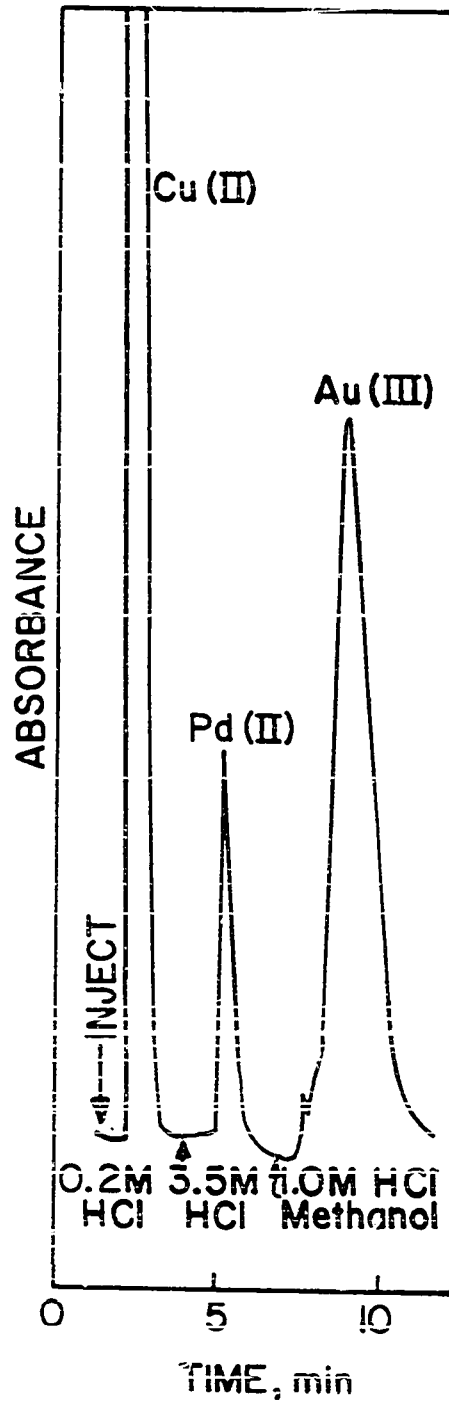

Figure 4. Separation of 1.3 mg copper(II), 2.1 μg palladium(II) and 9.8 μg gold(III)

Table I. Determination of platinum and gold in the presence of foreign metals

Foreign Metal	Pt(IV)		Au(III)	
	Molar Excess Foreign Metal	% Recovery Ave. of 2	Molar Excess Foreign Metal	% Recovery Ave. of 2
Mn(II)	200	100.8	1000	99.1
Fe(III)	200	99.2	1000	79.0
Fe(III)	---	----	500	98.2
Cr(III)	200	96.9	1000	99.8
Ni(II)	200	97.1	1000	99.0
Cu(II)	200	97.0	1000	98.7
Sr(II)	200	98.3	1000	99.2
Co(II)	200	97.7	1000	99.6
	Average Range		Average Range	
	2.3%		1.1%	

Table II. Determination of palladium and gold in the presence of foreign metals

Foreign Metal	Pd(II)		Au(III)	
	Molar Excess Foreign Metal	% Recovery Ave. of 3	Molar Excess Foreign Metal	% Recovery Ave. of 3
Mn(II)	1000	96.5	400	99.7
Fe(III)	1000	96.6	400	99.6
Cr(III)	1000	98.0	400	99.8
Ni(II)	1000	96.0	400	99.6
Cu(II)	1000	97.6	400	99.7
Sr(II)	1000	96.7	400	99.8
Ce(II)	1000	98.8	400	100.0
	Average Range		Average Range	
	1.7%		0.4%	

0.21 mequiv./g XAD-4. The sample is injected onto the column with an eluent of 0.2 M hydrochloric acid. After the major metal ion [iron(III)] has eluted, bismuth(III) is eluted with 2.2 M hydrochloric acid. Mercury(II) is eluted with 8.5 M hydrochloric acid. A larger column was used for this separation, which permitted samples to be dissolved in up to 2 M hydrochloric acid with no premature bleeding of the bismuth(III).

The results in Table III show the method is quite selective. Samples containing antimony(III) and tin(IV) have a different baseline shift which is caused by bleeding of the residue metals. However, this effect is not serious and recovery is still good. Silver(I) interferes with bismuth(III) when detection is at 225 nm. Changing to 327 nm eliminates this interference because silver(I) no longer absorbs.

Separation of tin(IV) from other metals

Satisfactory separations of tin(IV) and nickel(II) have been obtained on 0.21 mequiv./g XAD-4. The sample is dissolved in approximately 5 M hydrochloric acid and is injected on the column. Nickel(II) and other metals are eluted with 5.0 M hydrochloric acid. Tin(IV) is eluted with 1.0 M hydrochloric acid. There is a solvent change peak preceding the tin(IV) peak, but a linear calibration

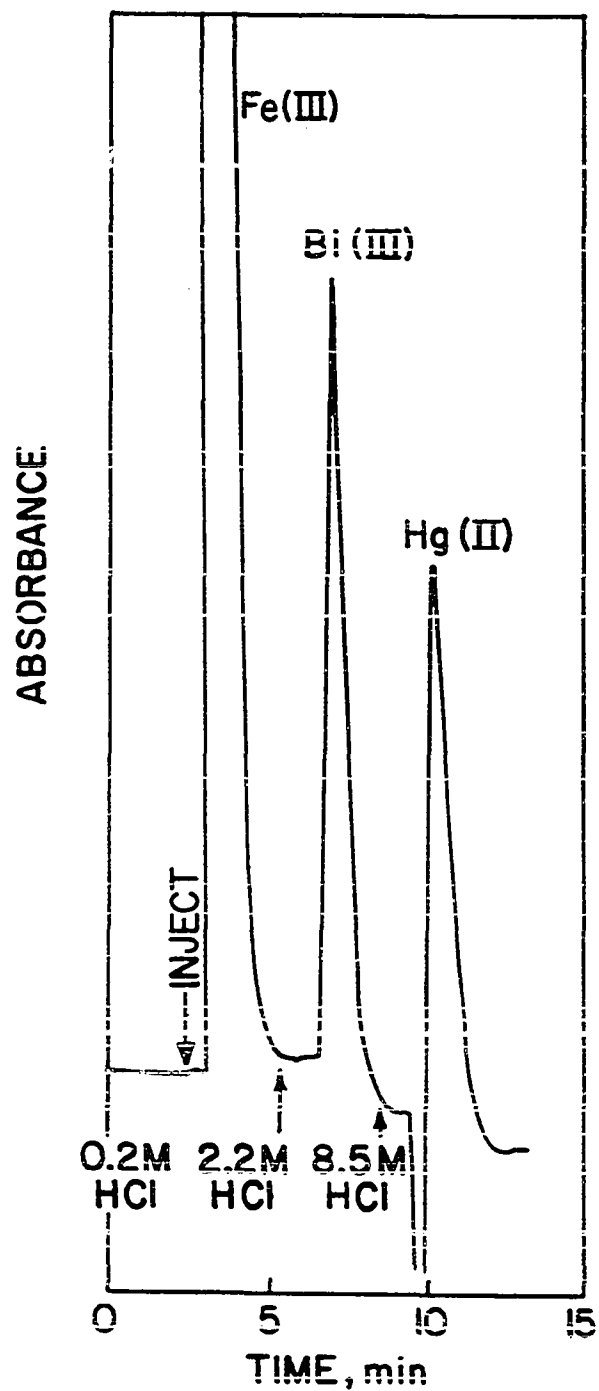

Figure 5. Separation of 2.2 mg iron(III), 4.2 μg bismuth (III) and 4.0 μg mercury(II)

Table III. Determination of bismuth and mercury in the presence of foreign metals

Foreign Metal	Bi(III)		Hg(II)	
	Molar Excess Foreign Metal	% Recovery Ave. of 3	Molar Excess Foreign Metal	% Recovery Ave. of 3
Cu(II)	1000	99.7	1000	99.8
Cr(III)	1000	100.1	1000	100.6
Fe(III)	1000	101.9	1000	100.0
Mn(II)	1000	99.2	1000	100.2
Sr(II)	1000	99.3	1000	99.6
Ni(II)	1000	100.0	1000	100.9
Co(II)	1000	100.5	1000	100.7
Zn(II)	1000	100.1	1000	102.7
Cd(II)	1000	99.7	1000	101.1
Sn(IV)	100	98.8	100	101.9
As(III)	100	98.9	100	100.2
Pb(II)	20	101.2	20	101.3
Sb(III)	20	100.6	20	104.4
Ag(I) $\lambda=225\text{nm}$	1	>150	1	99.9
Ag(I) $\lambda=327\text{nm}$	1	99.0	1	----
	Average Range		Average Range	
	1.3%		1.5%	

curve of peak height vs. μg of tin(IV) was obtained nevertheless. Data for determination of tin(IV) in the presence of other metal ions are given in Table IV.

Separation of copper(II), palladium(II) and platinum(IV)

When a column of high performance is used, palladium (II) and platinum(IV) can be easily separated from each other and a nonretained metal such as copper(II). The chromatogram in Figure 6 shows this separation on 0.04 mequiv./g XAD-1. The peaks given by platinum represent two different complexes of platinum(IV).

Table IV. Determination of tin in the presence of foreign metals

Foreign Metal	Sn(IV)	
	Molar Excess Foreign Metal	% Recovery Ave. of 3
Cu(II)	100	100.9
Cr(III)	100	100.5
Ni(II)	100	100.6
Zn(II)	100	99.7
As(III)	100	interferes
Sb(III)	100	interferes
Average Range		
1.3%		

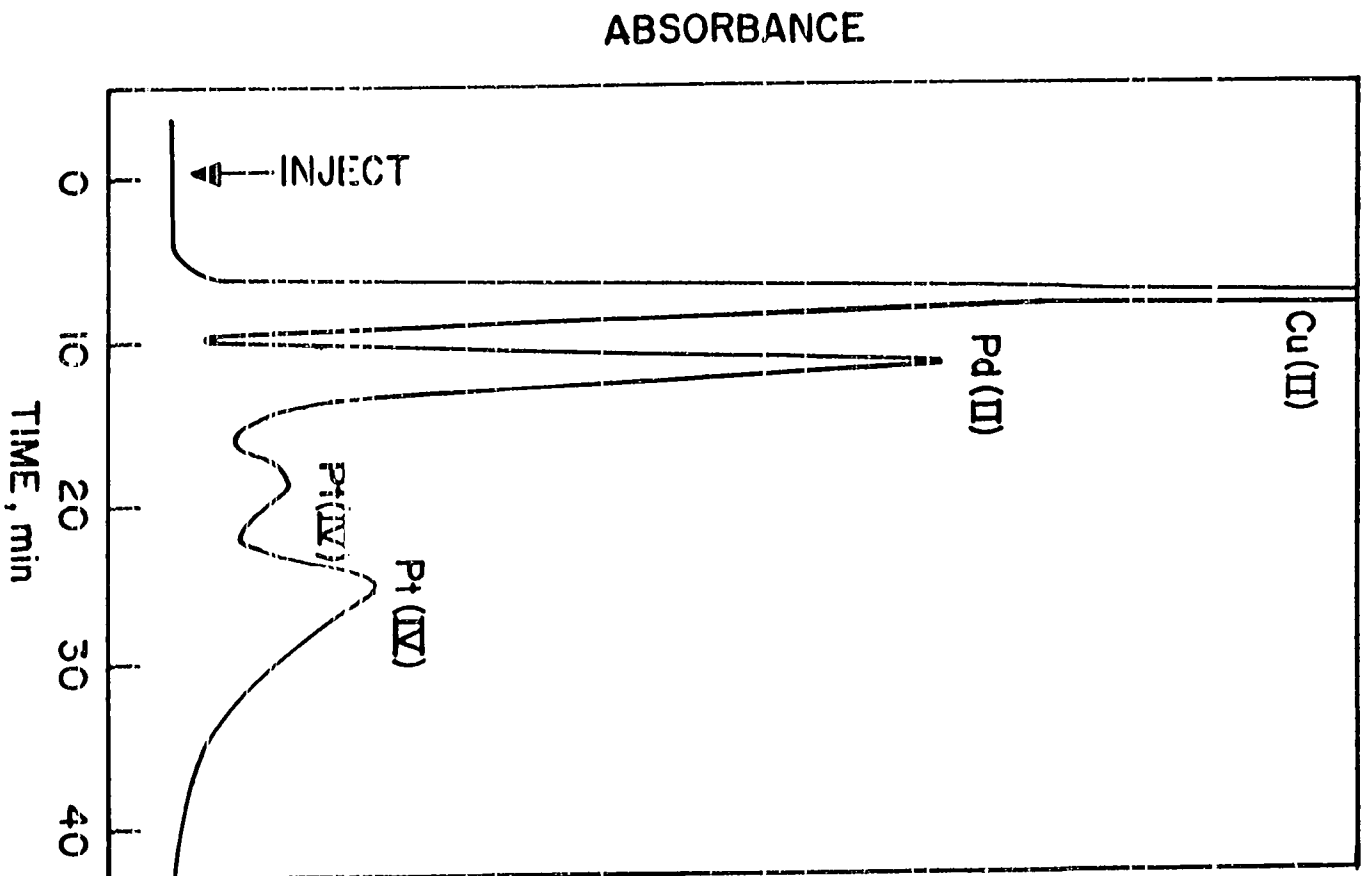

Figure 6. Separation of copper(II), palladium(II) and platinum(IV)

CONCLUSIONS

Ion-exchange resin capacity can be easily varied and it is a parameter to be considered when devising analytical separations. Low-capacity anion-exchange resins permit elution of many metal chloro complexes that previously were difficult or impossible to elute. XAD anion-exchange resins have excellent mechanical and chemical stability and lend themselves well to a forced flow system with automatic detection.

REFERENCES

1. Kraus, K. A.; Nelson, F. Symposium on Ion Exchange and Chromatography in Analytical Chemistry. ASTM Special Publication No. 195, American Society for Testing Materials: Philadelphia, 1958; p 27-57.
2. Kraus, K. A.; Nelson, F. Proceedings International Conference on Peaceful Uses of Atomic Energy: United Nations, 1956, 7, 113, 131.
3. Kraus, K. A.; Moore, G. E. J. Am. Chem. Soc. 1953, 75, 1460.
4. Moore, G. E.; Kraus, K. A. J. Am. Chem. Soc. 1952, 74, 843.
5. Wilkins, D. H.; Hibbs, L. E. Analyt. Chim. Acta 1959, 20, 271.
6. Wilkins, D. H. Analyt. Chim. Acta 1959, 20, 271.
7. Wilkins, D. H. Analyt. Chim. Acta 1958, 18, 372.
8. Goodkin, J. L.; Seymour, M. D.; Fritz, J. S. Talanta 1975, 22, 245.
9. Seymour, M. D.; Sickafoose, J. P.; Fritz, J. S. Anal. Chem. 1971, 43, 1734.
10. Seymour, M. D.; Fritz, J. S. Anal. Chem. 1973, 45, 1394.
11. Gjerde, D. T.; Fritz, J. S. J. Chromatogr. 1979, 176, 199.
12. Fritz, J. S.; Story, J. H. J. Chromatogr. 1974, 90, 267.
13. Fritz, J. S.; Story, J. N. Anal. Chem. 1974, 46, 825.
14. King, J. N.; Fritz, J. S. J. Chromatogr. 1978, 153, 507.

SECTION III.

ANION CHROMATOGRAPHY WITH LOW-CONDUCTIVITY ELUENTS I

INTRODUCTION

In recent years there has been a growing need for reliable analytical methods for the rapid, simultaneous determination of mixtures of common anions in dilute, aqueous solutions. Not until the development by Small, Stevens and Bauman (1) of the procedure which they call "Ion Chromatography" has the rapid separation and quantitative determination of inorganic anions (and certain cations) become possible. Their system, which is marketed as a commercial instrument by the Dionex Corp., uses a separation column containing a patented anion-exchange resin. The separated anions are detected by conductance after passing through a hydrogen-form cation-exchange column (called a suppressor column) to remove most of the background conductance of the eluent.

This commercial instrument, called the "Ion Chromatograph", permits good resolution of many anion mixtures with high sensitivity, and it has therefore found many applications, especially in the analysis of environmental samples (2). A major disadvantage of this instrument is that it uses a suppressor column that accumulates the ions from the eluent stream and which must be regenerated periodically to remove the unwanted ions. Another drawback is that the eluent must be a base, so that after neutralization by the suppressor column it will have a low

conductivity. A solution of sodium carbonate and sodium bicarbonate is the most commonly used eluent. Anions of very weak acids cannot be detected on the "Ion Chromatograph" because their acidic form is too weakly conducting.

This paper describes a very simple chromatographic system that permits a quick and quantitative separation of several common anions. The new system for anion chromatography uses a conductivity detector but requires no suppressor column. This has been achieved by two principal innovations: (1) use of a special anion-exchange resin of very low capacity and (2) the adoption of an eluent having a very low conductivity. The eluents used were approximately a 5.0×10^{-4} M aqueous solutions of potassium benzoate, potassium phthalate or ammonium o-sulfobenzoate. Very sharp separations of anions could be achieved, and in no case did the absence of a suppressor column prove to be an obstacle.

EXPERIMENTAL

Sample solution

Standard solutions of the potassium salts of various anions (fluoride, chloride, sulfate, etc., as shown in the chromatograms) were prepared from analytical-grade reagents.

Ion-exchange resins

Two kinds of ion exchangers served as the stationary phase of the analytical column, viz. the relatively high-capacity, commercially available Vydac SC anion-exchange resin (bead size: 30-44 microns, capacity: 0.1 mequiv/g), and three low-capacity anion-exchange resins prepared at this laboratory by the following method:

The copolymer used as starting material for the synthesis of the anion-exchange resins was Rohm and Haas' macroreticular crosslinked poly (styrene-divinylbenzene) beads known as XAD-1. This resin is highly crosslinked and has excellent chemical and mechanical stability. The beads were ground and sieved, and the fraction of 150-160 mesh was collected for the synthesis.

A 3 g portion of that fraction was swollen in a mixture of 10 mL chloromethylmethyl ether, 10 mL methylene chloride and 3 mL nitromethane. When 3 g of zinc chloride were added to the mixture the reaction was initiated and was maintained at room temperature for up to 14 minutes,

after which the reaction was quenched by adding water to the mixture. The beads were then filtered, washed with water and methanol and finally air dried.

The chloromethylated beads were aminated by adding liquefied trimethylamine and allowing the excess amine to evaporate overnight. The final product was washed with 1 M HCl, 2-propanol and water, and was dried overnight at 60°C.

Anion-exchange resins of three different capacities were prepared. The first had a capacity of 0.04 mequiv./g, the second a capacity of 0.07 mequiv./g and the third a capacity of 0.007 mequiv./g.

Eluents

The following eluents were used:

1. Potassium benzoate: 6.5×10^{-4} M pH = 4.6,
specific conductance = 6.59×10^{-5} mho/cm.
2. Potassium phthalate: 5×10^{-4} M pH = 4.40,
specific conductance = 7.43×10^{-5} mho/cm
 5×10^{-4} M pH = 6.20, specific conductance =
 1.12×10^{-4} mho/cm 6.5×10^{-4} M pH = 4.40,
specific conductance = 9.05×10^{-5} mho/cm
 6.5×10^{-4} M pH = 6.20, specific conductance =
 1.58×10^{-4} mho/cm.

3. Ammonium o-sulfobenzoate: 5×10^{-4} M pH = 5.8,
specific conductance = 1.32×10^{-4} mho/cm.

Apparatus

The chromatographic flow system used, shown in Figure 1, consisted of the following parts:

1. A Milton-Roy pump (Model 396 Simplex) which serves to force the eluent to flow at 2 mL/min. through the sample loop, the analytical column, and the conductivity cell.
2. A sample injection valve which makes use of a sample loop and enables liquid increments as small as 50-100 microliters to be injected.
3. Two different analytical separation columns: for the Vydac resin and the XAD-1, 0.007 mequiv./g resin, the dimensions of the column were 3 mm i.d. and 500 mm length; for the low-capacity XAD-1, 0.04 mequiv./g, a column 2 mm i.d. and 1000 mm long was used.
4. A fluid conductivity cell assembly which measures the conductivity of the solution emerging from the analytical column.
5. A conductivity detector which continuously monitors the conductivity of the effluent.

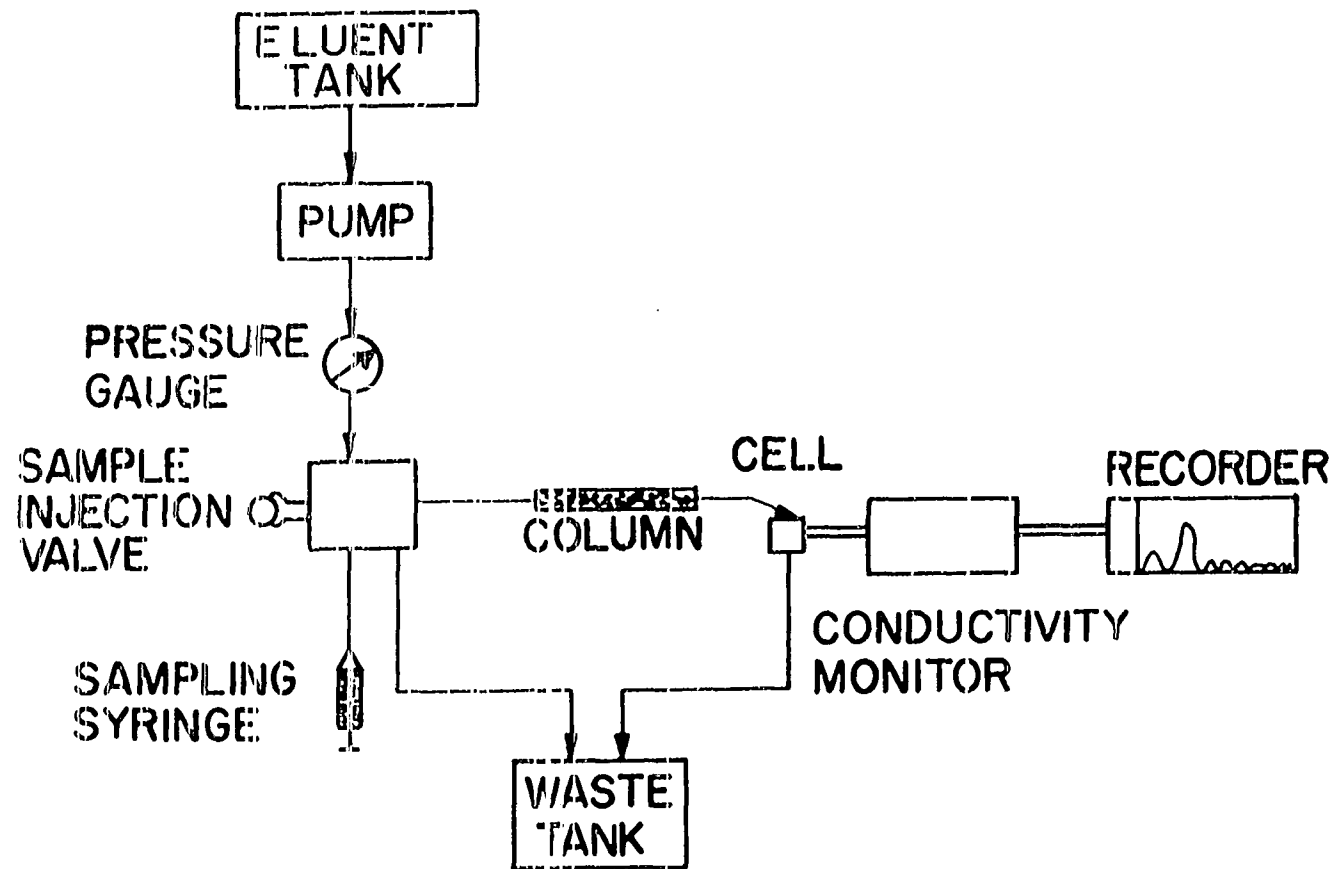

Figure 1. Schematic representation of the liquid chromatograph

6. A recorder, which traces the output of the conductivity meter.

Initially, the eluent must be pumped through the system for 15-30 minutes before the baseline is stabilized and the sample can be injected. The back pressure for the column of XAD resin is approximately 200 psi; that for the column of Vydac resin is about 450 psi.

RESULTS

Eluent

The eluent anion must be retained by the anion-exchange resin strongly enough that a very low concentration of the eluent salt will move anions to be separated down the chromatographic column. At the same time the conductance of the eluent should be low so that the separated anions (with an appropriate cationic counter ion) will give a detector signal well above that of the eluent background.

Potassium acid phthalate, pH 4.4, 5.0×10^{-4} M, was the first eluent tried. It gave well-defined peaks for separation of simple mixtures of two or three common anions using a low-capacity (0.04 mequiv./g) XAD-1 resin column and a conductance detector. Further investigation revealed that 5.0×10^{-4} M solutions of potassium benzoate, potassium phthalate, and ammonium sulfobenzoate (all at pH 6) are excellent eluents. A 6.5×10^{-5} M solution of potassium malonate, pH 6.1, is a much less effective eluent than any of the three listed above. Apparently, a benzene ring in the chemical structure of the eluent salt plays a major role in enabling inorganic anions to be effectively eluted from the XAD-1 resin. Similarly, a 5.0×10^{-4} M solution of potassium perchlorate or potassium malonate was a rather ineffective eluent. Adjusted retention times for

elution of inorganic anions with various eluents are summarized in Table I. Several experiments indicated that there is little difference in effectiveness between the potassium and sodium salts of the different eluents.

Of the three recommended eluents, potassium benzoate has the mildest eluting ability. Using 0.04 mequiv./g XAD-1 resin and 5.0×10^{-4} M benzoate, an excellent separation of fluoride, chloride and bromide was obtained (see Figure 2). There is an interest in separating nitrate and nitrite; Figure 3 shows excellent resolution of these two anions using benzoate eluent. However, benzoate is not an effective eluent for ions that are more tenaciously held by the XAD-1 resin, such as sulfate, iodide and thiocyanate.

Phthalate is intermediate in eluting ability of the three recommended eluents. Using a 5.0×10^{-4} M solution, anions are eluted more quickly when the eluent pH is raised from 4.4 to 6.1 (see Table I). For sulfate the pH effect is quite dramatic, the adjusted retention time going from 16.4 minutes at pH 4.4 to only 4.4 minutes at pH 6.1. However, thiocyanate has almost the same adjusted retention time at the two pH values (14.7 minutes and 15.0 minutes). The retention time of iodide changes only slightly with pH. Since more of the phthalate is present as the divalent anion at pH 6.1, it would be expected to be a better

Table I. Adjusted retention times (min) of anions on XAD-1, 0.04 mequiv./g with different eluents ($t_c = 1.8$ min)

Eluent Ion	benzoate 5×10^{-4} M, pH = 6.0	phthlalate 5×10^{-4} M, pH = 4.4	phthalate 5×10^{-4} M, pH = 6.1	sulfobenzoate 5×10^{-4} M, pH = 5.8	perchlorate 5×10^{-4} M, pH = 7.0	malonate 6.5×10^{-4} M, pH = 6.1
F ⁻	2.8	0.8	0.0	0.0	-- ^a	-- ^a
Cl ⁻	3.9	1.3	0.7	0.7	5.8	4.2
NO ₂ ⁻	4.8	1.4	0.8	1.3	-- ^a	3.8
Br ⁻	6.3	2.1	1.3	1.1	8.6	4.6
NO ₃ ⁻	7.2	2.2	1.4	1.3	9.4	6.7
SO ₄ ⁼	-- ^b	16.4	4.4	3.3	-- ^b	-- ^b
I ⁻	-- ^b	6.3	5.4	-- ^b		
SCN ⁻	-- ^b	14.7	15.0	-- ^b		
C ₂ O ₄ ⁼			5.0	3.5		
CrO ₄ ⁼			0.8	0.5		
SO ₃ ⁼			4.5	3.2		
S ₂ O ₃ ⁼			7.5	5.1		

^aNegative or multiple peak

^bVery long retention times

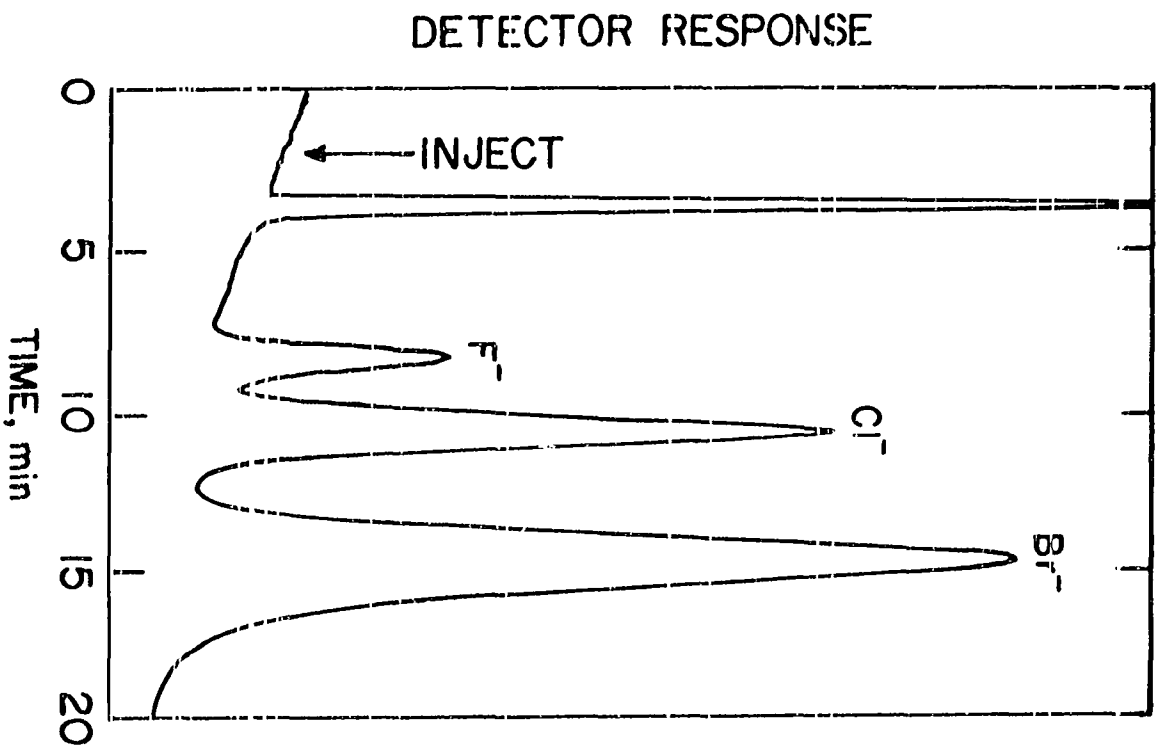

Figure 2. Separation of 4.8 ppm fluoride, 5.1 ppm chloride and 26.0 ppm bromide; Resin; XAD-1 0.04 mequiv./g; Eluent: 6.5×10^{-4} M potassium benzoate, pH = 4.6

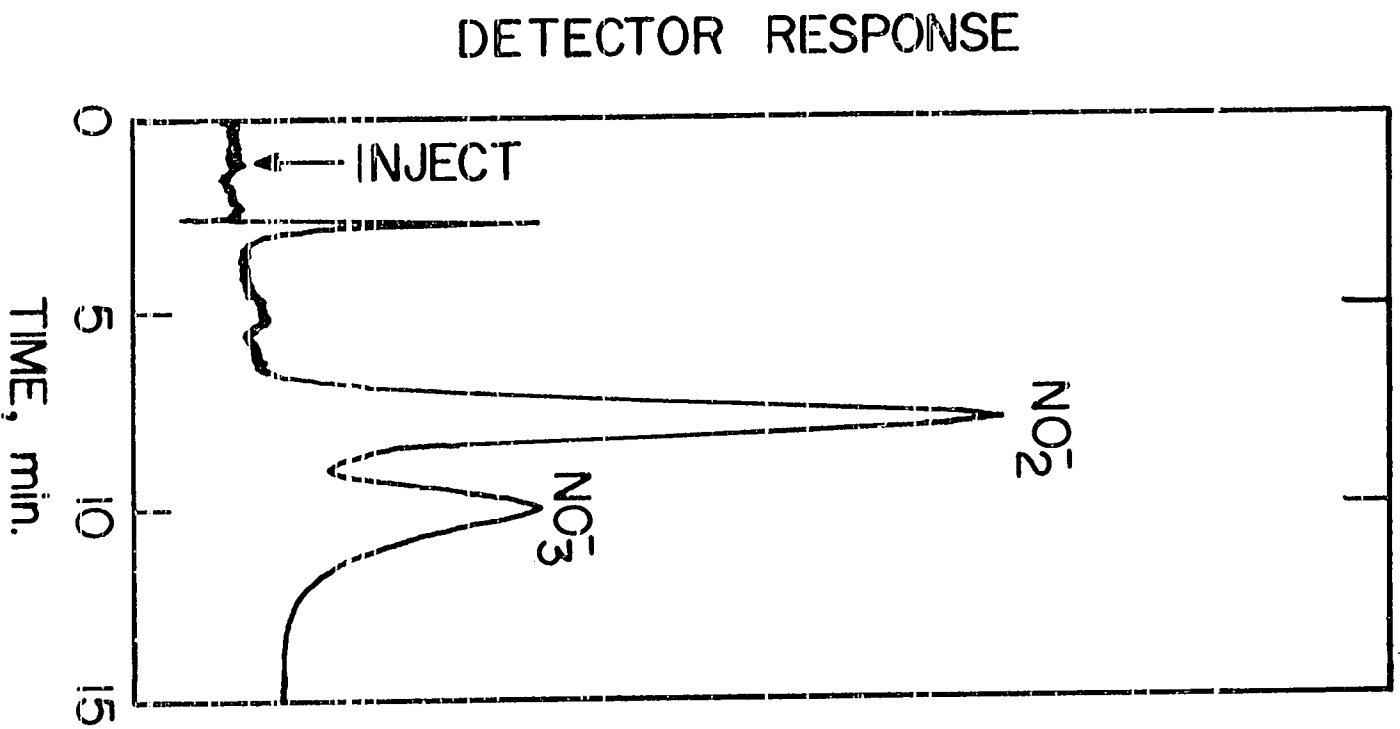

Figure 3. Separation of 16.0 ppm nitrite and 12.2 ppm nitrate; Resin: XAD-1 0.04 mequiv./g; Eluent: 6.5×10^{-4} M potassium benzoate, pH = 5.0

eluent at the higher pH. The background conductivity is greater at pH 6.1, making the anion peak heights lower. Figure 4 shows the chromatogram for a mixture containing five different anions.

Ammonium o-sulfobenzoate, pH 5.8, was the most effective salt for eluting divalent anions, which are usually very strongly retained on the resin. The adjusted retention time of the chromate ion, for instance, is only 0.5 minutes on the 0.04 mequiv./g XAD-1 resin using 5.0×10^{-4} M sulfobenzoate. This retention time compares very favorably with the 25 minute retention time obtained in the Dionex system using a mixture of sodium bicarbonate and sodium carbonate as the eluent. The retention time of the oxalate anion is 3.5 minutes with sulfobenzoate and XAD-1 anion-exchange resin, compared with 18 minutes in the Dionex system. An excellent separation of sulfate and thiosulfate is shown in Figure 5 with sulfobenzoate at pH 7.3 as the eluent.

Resin

The type and capacity of an anion-exchange resin are important variables in anion chromatography. Rohm and Haas XAD-1, a macroporous poly (styrene-divinylbenzene) resin, was converted to an anion-exchange resin of low capacity by chloromethylation under very mild conditions, followed by amination with trimethylamine. This resin has excellent

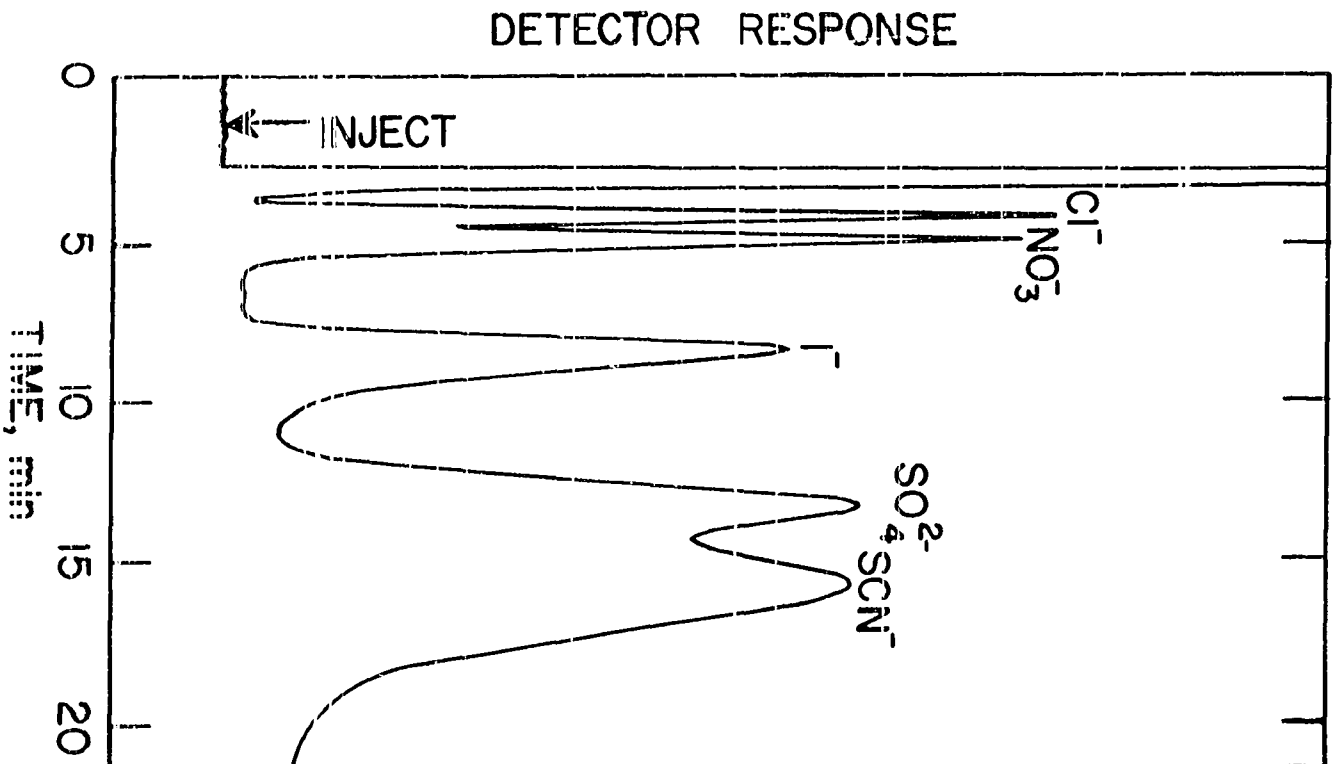

Figure 4. Separation of 5.1 ppm chloride, 12.2 ppm nitrate, 39.0 ppm iodide, 44.1 ppm sulfate and 28.6 ppm thiocyanate; Resin: XAD-1 0.04 mequiv./g; Eluent: 6.5×10^{-4} M KHP, pH = 4.4

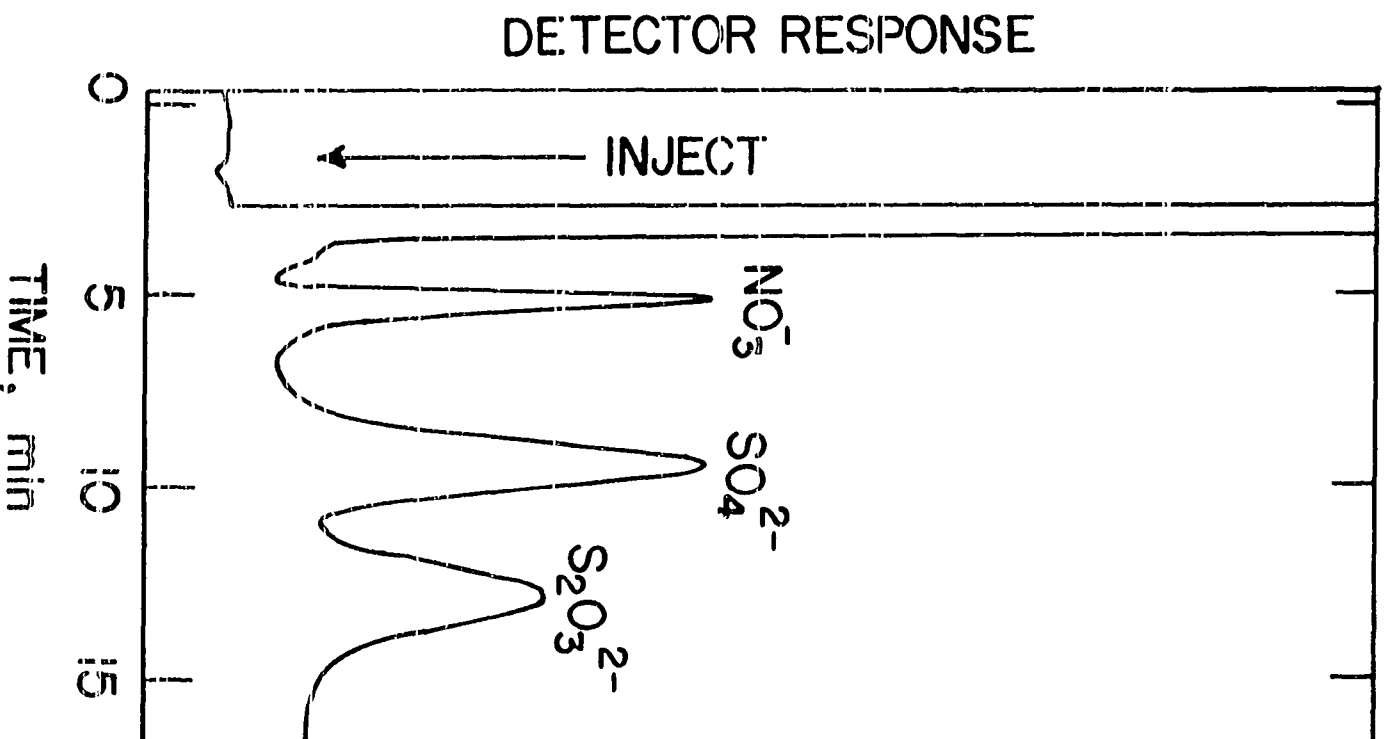

Figure 5. Separation of 24.4 ppm nitrate, 22.0 ppm sulfate and 21.3 ppm thiosulfate; Resin: XAD-1 0.04 mequiv./g; Eluent: 5×10^{-4} M ammonium o-sulfobenzoate, pH = 7.3

physical properties and is well suited to column chromatography under pressure. Most of the work was done with XAD-1 anion-exchange resin having a capacity of 0.04 mequiv./g. However, an XAD-1 resin of 0.07 mequiv./g and a third resin of very low capacity (0.007 mequiv./g) were also prepared and tested.

For several monovalent anions Gjerde and Fritz (3) showed that the selectivity coefficient is largely independent of resin capacity over the capacity range studied, 0.1 to 1.0 mequiv./g. It follows from this that the concentration of an anionic eluent required to elute any given anion from a resin column decreases with decreasing resin capacity. This is confirmed by the data in Table II, which compares the adjusted retention times of a number of anions from resin columns of different capacity. The data show appreciably longer retention times for all anions on the 0.07 mequiv./g resin compared to the 0.04 mequiv./g resin. Anions are eluted efficiently from the resin column at the lowest capacity (0.007 mequiv./g) by a phthalate eluent that is only 1.0×10^{-4} M or a benzoate eluent of only 2×10^{-4} M. Using eluents of such low conductivity enhances the sensitivity of the system, and consequently, quantitative determinations of chloride and nitrate below 1 ppm could be achieved using this low-capacity resin.

Table II. Comparative adjusted retention times (min) for XAD-1 0.04 mequiv./g, XAD-1 0.07 mequiv./g and XAD-1 0.007 mequiv./g

Ion	0.07 mequiv./g ^a	0.04 mequiv./g ^a	0.007 mequiv./g ^b
F ⁻	0.6	0.0	0.6
Cl ⁻	1.5	0.7	1.0
NO ₂ ⁻	2.0	0.8	1.4
Br ⁻	3.8	1.3	1.2
NO ₃ ⁻	4.5	1.4	1.5
SO ₄ ²⁻	11.5	4.4	5.5
I ⁻	-- ^c	5.4	2.0
CNS ⁻	-- ^c	15.0	4.0
C ₂ O ₄ ²⁻	12.8	5.0	5.7
CrO ₄ ²⁻	1.3	0.8	3.4
SO ₃ ²⁻	11.6	4.5	5.8
S ₂ O ₃ ²⁻	-- ^c	7.5	8.1

^aEluent: 5×10^{-4} M KHP, pH = 6.0 t_0 = 1.8 min; Column: 2 mm i.d. x 1000 mm

^bEluent: 1×10^{-4} M KHP, pH = 7.1 t_0 = 1.5 min; Column: 3 mm i.d. x 500 mm

^cVery long retention times

The XAD-1 resin of 0.007 mequiv./g capacity is excellent for separation of anions that elute slowly from other resin columns. With 1.0×10^{-4} M phthalate (pH 7.1) as eluent, chloride, bromide and nitrate elute together, but ions such as iodide, thiocyanate, sulfate and thio-sulfate have different retention times. Figure 6 shows an excellent separation of chloride, iodide, thiocyanate and sulfate; the last two ions are much better resolved than on the high capacity resin used in Figure 4. A nice separation of chromate, sulfate and thiosulfate is shown in Figure 7. Furthermore, well defined peaks could be obtained for HPO_4^{2-} and ClO_4^- which could not be achieved with the higher capacity resins.

Since elution behavior of anions is highly dependent on resin capacity, separations will vary from one batch of resin to the next unless the resin capacity is carefully controlled. Fortunately, resin capacity can be reproduced very nicely by controlling the conditions used for chloromethylation; two batches of resin had identical capacities (0.04 mequiv./g) and behaved similarly in actual use.

Several experiments were performed with a commercially-available resin, Vydac SC. This is a solid core silica resin with an organic anion-exchange resin chemically bonded to the porous surface layer of the resin beads. The anion-exchange capacity is listed by the manufacturer as

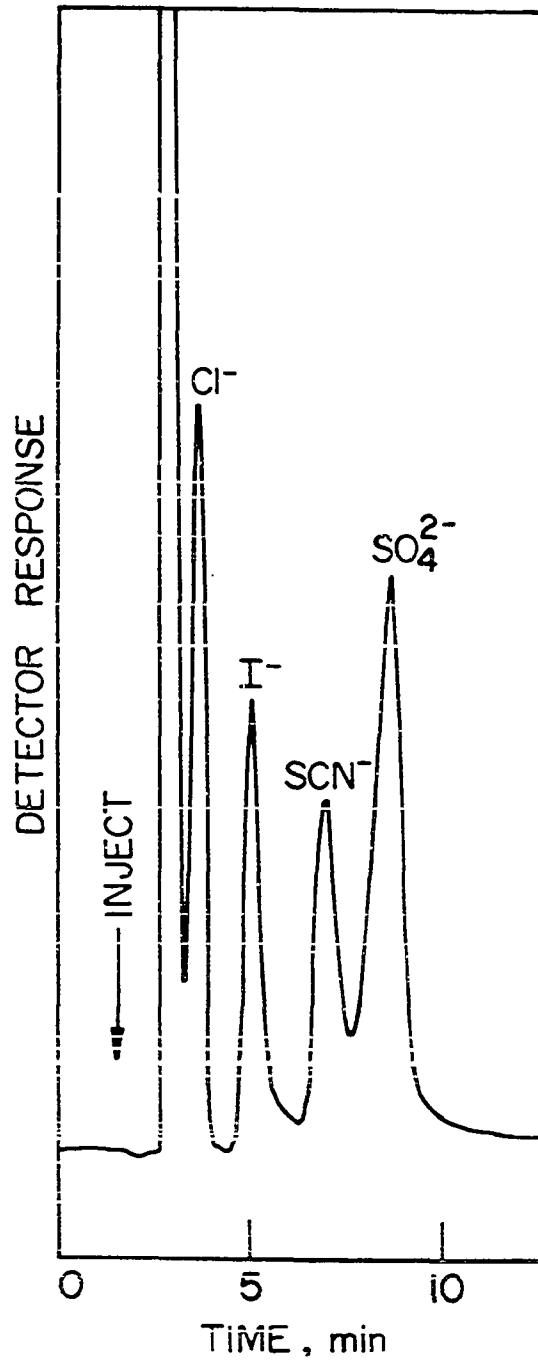

Figure 6. Separation of 7.7 ppm chloride, 29.5 ppm iodide, 28.6 ppm thiocyanate and 16.5 ppm sulfate; Resin: XAD-1 0.007 mequiv./g; Eluent: 1×10^{-4} M KHP, pH = 7.1

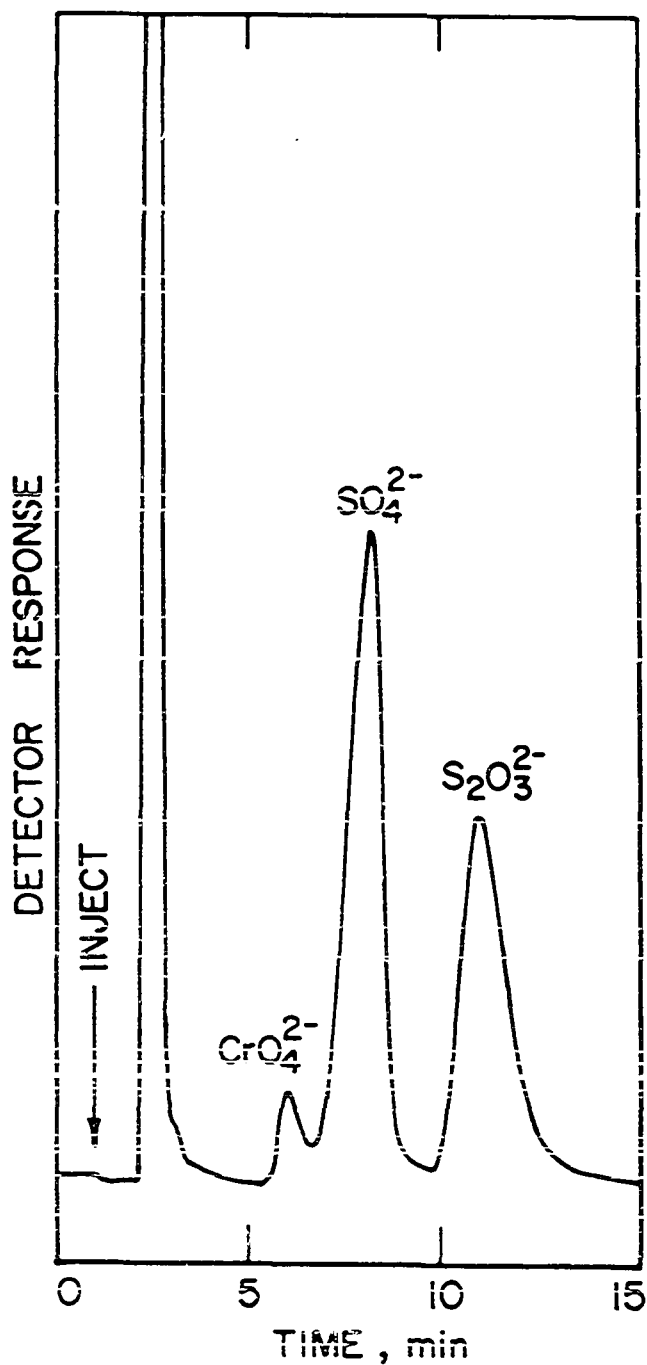

Figure 7. Separation of 17.8 ppm chromate, 22.0 ppm sulfate and 21.3 thiosulfate; Resin: XAD-1 0.007 mequiv./g; Eluent: 1×10^{-4} M KHP, pH = 7.1

0.10 mequiv./g. Vydac is a proprietary resin and the exact nature of the organic part is unknown, although it does appear to contain a quaternary ammonium functional group.

The performance of a 50-cm column packed with Vydac SC was very good. Figure 8 shows an excellent separation of five anions. The resolution was much better than for similar separations attempted on a XAD-1 anion-exchange column. The relative retention times of different anions on Vydac are different from those obtained on XAD-1. Nitrate, in particular, elutes quite late from a Vydac column.

Some practical applications

The applicability of the method to real samples was demonstrated by a number of practical examples.

Determination of sulfate in water The quantitative determination of ppm concentrations of sulfate in water is a widely studied problem; often a turbidimetric or spectrophotometric procedure is used for the analysis (4). Low concentrations of sulfate can be separated rapidly by anion chromatography, as shown in Figure 9. Using an appropriate calibration plot, an accurate quantitative determination of the sulfate is possible.

The efficacy of the chromatographic method was demonstrated by separating a series of samples containing chloride,

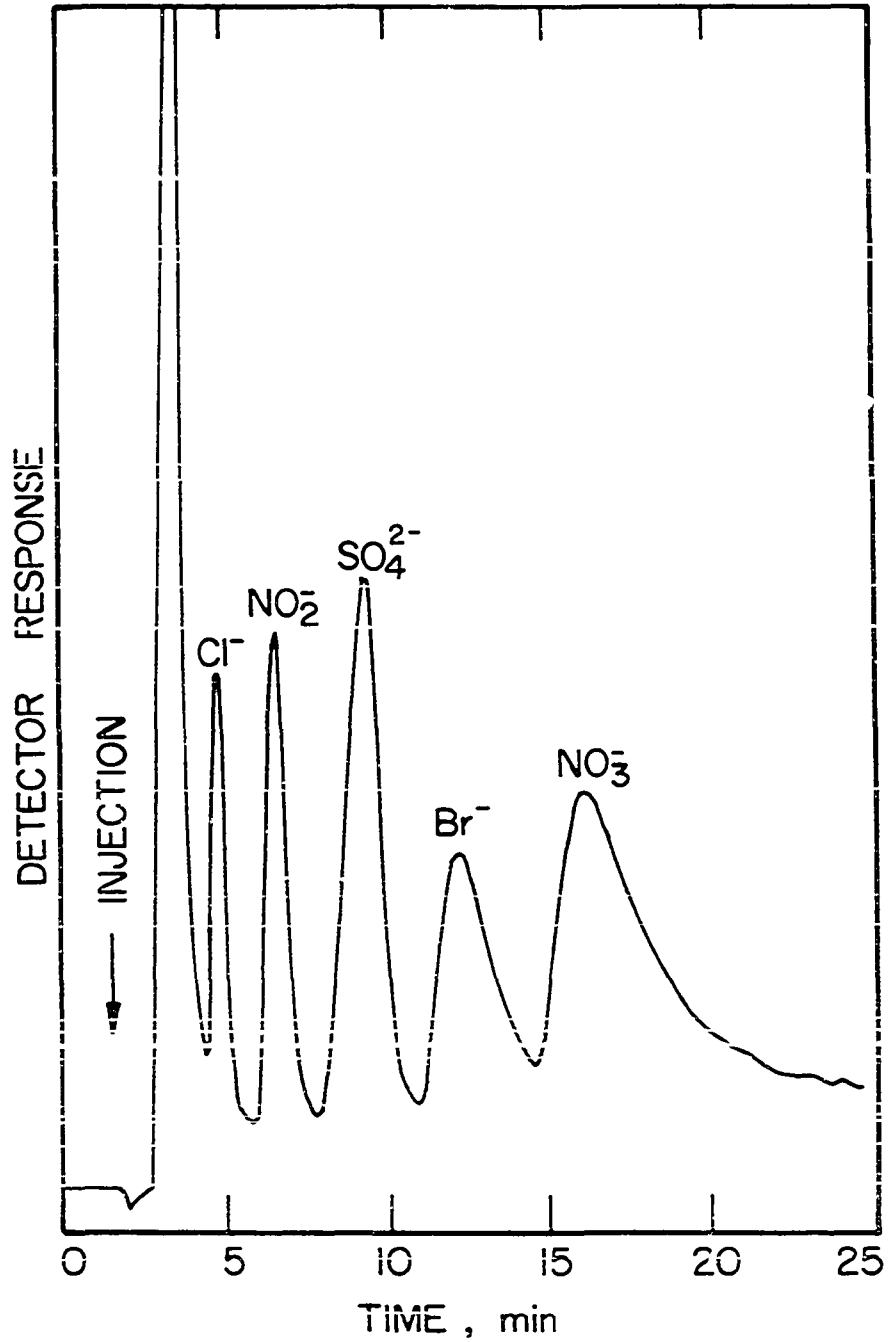

Figure 8. Separation of 5.1 ppm chloride, 16.0 ppm nitrite, 22.0 ppm sulfate, 26.0 ppm bromide, and 39.5 ppm nitrate; Resin: Vydac SC anion exchange; Eluent: 5×10^{-4} M KHP, pH = 6.0

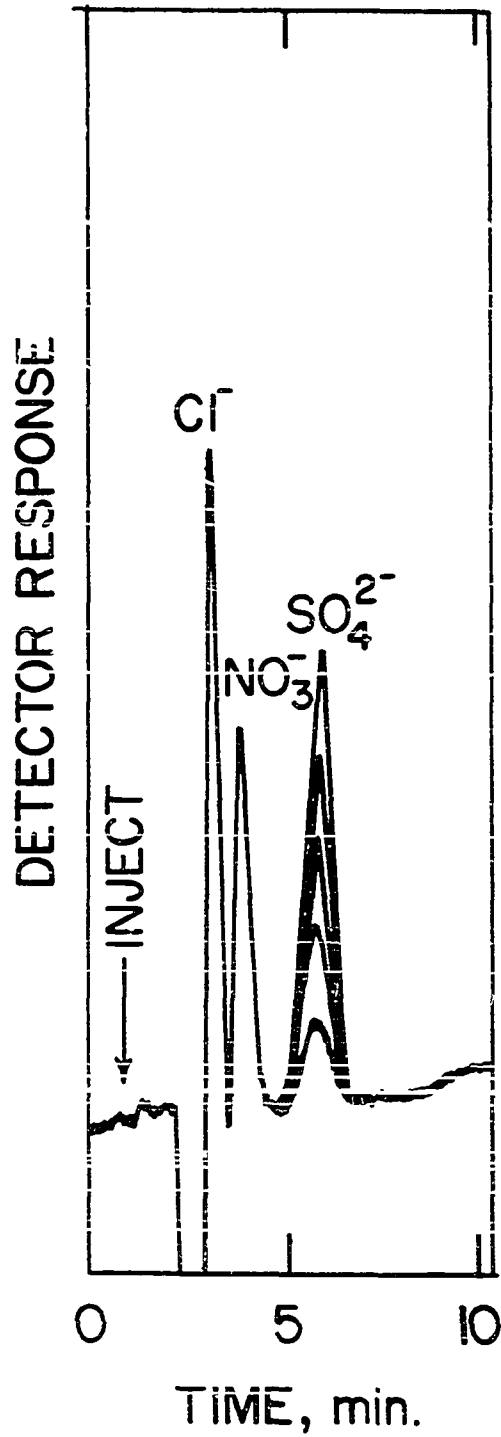

Figure 9. Separation of standard solutions of sulfate, 2.75 ppm to 13.75 ppm, from chloride and nitrate: Resin: XAD-1 0.04 mequiv./g; Eluent: 5×10^{-4} M KHP, pH = 6.2

nitrate and sulfate on a 50-cm XAD-1 column with 6.5×10^{-4} M potassium phthalate (pH 6.2) as the eluent. The chloride and nitrate concentrations were held constant at 5.12 and 12.2 ppm, respectively, while the sulfate concentration was varied from 2.75 ppm to 13.75 ppm. A plot of sulfate peak height vs. concentration proved to be perfectly linear, so that an accurate quantitative determination of sulfate was possible. The chromatograms obtained point to the possible use of the new chromatographic system for routine water analysis for the simultaneous determination of three anions.

Determination of nitrite in tap water Because of its deleterious effects, there is a great interest in controlling the nitrite concentration in drinking water. Figure 10 shows a chromatogram of tap water taken with a Vydac column and 5.0×10^{-4} M phthalate eluent at pH 6.0. The small peak between chloride and sulfate with a retention time of 5.2 minutes was identified as nitrite. Standard additions of nitrite to the tap water increased the height of the nitrite peak and yielded a linear correlation between peak height and nitrite added. Extrapolation of this plot to zero added nitrite gave a nitrite concentration of 0.37 ppm in laboratory tap water.

Determination of nitrite and nitrate in curing salt
This product consists largely of ordinary table salt with

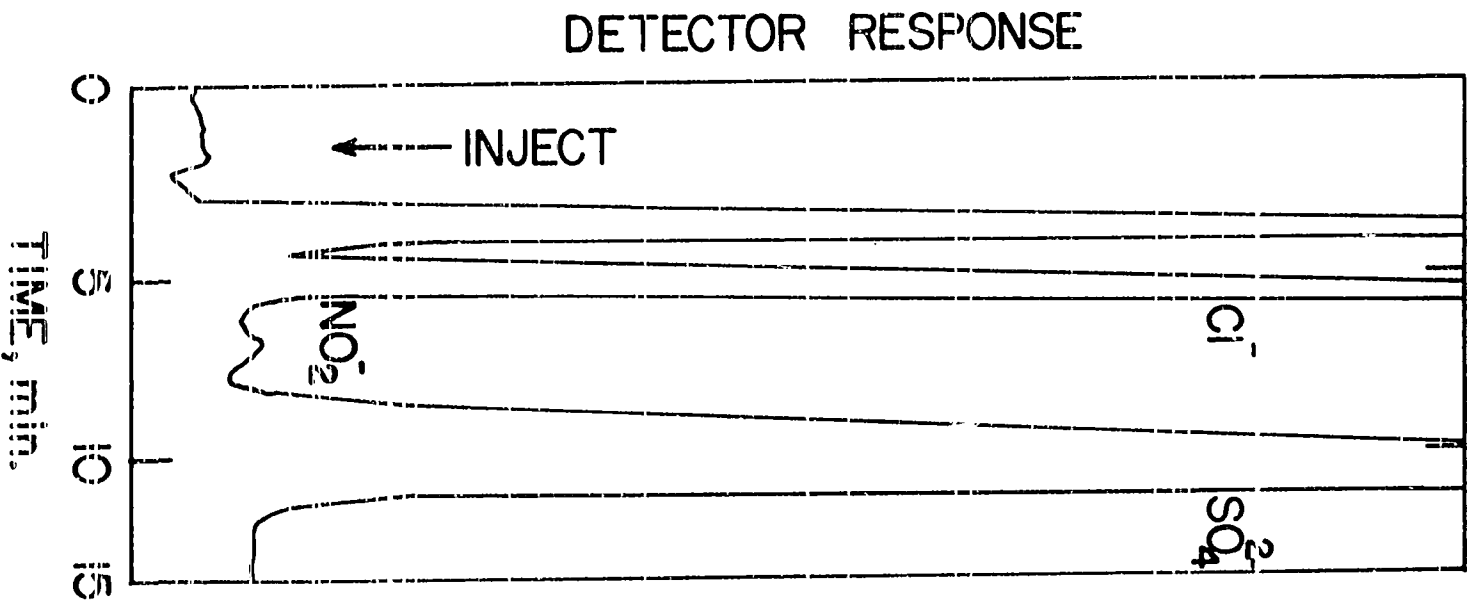

Figure 10. Separation of 0.37 ppm nitrite from chloride and sulfate in ISU tap water; Resin: Vydac SC anion exchange; Eluent: 5×10^{-4} M KHP, pH = 6.0

small quantities of sodium nitrite and sodium nitrate added. The analytical problem was to determine these added salts in the presence of large amounts of sodium chloride. Nitrite was determined by injecting a sample containing 0.5 g/L of curing salt onto a Vydac column and eluting with the same eluent as used in the previous example. Then several chromatograms were recorded in which increasing amounts of nitrite were added. From a linear plot of peak height vs. nitrite added, the sodium nitrite concentration of the curing salt was found to be 0.27%.

A solution containing 4 g/L of curing salt was found to be necessary to obtain a well-defined peak for nitrate. The column and eluent were the same as used for the nitrite determination, but the retention time for nitrate was 16.5 minutes. Standard additions of nitrate again resulted in a linear dependence between peak height and concentration. Extrapolation of the plot gave a concentration of 0.34% sodium nitrate in the curing salt.

DISCUSSION

A feature common to all the chromatograms is the very first peak, which is related to the total concentration of the sample salts injected and is called the "pseudo peak". When a sample is injected onto the column, the anions present in the sample replace the eluent anion from the anion-exchange resin at the top of the column. The displaced eluent anions, together with the sample cations, move with the solvent front to the conductivity detector. If this concentration of cations and anions is such that the conductance is greater than that of the eluent background, there will be a positive peak. In cases where the concentration is less than the eluent background, a negative peak will result.

The XAD-1 anion exchangers used in this work appear to have much stronger hydrophobic interactions with anions than with more conventional anion exchange resins. For example, iodide, thiocyanate, and other anions that are easily dehydrated are not eluted from 0.04 mequiv./g XAD-1 by most ionic eluents. Actually, the resin environment is rather strongly hydrophobic with only about one benzene ring in 200 derivatized with the ionic quaternary ammonium functional group. The $-\text{CH}_2\overset{\oplus}{\text{N}}(\text{CH}_3)_3\text{I}^-$ (or SCN^-) ion pair is stabilized by interaction with the hydrophobic resin environment, making it difficult to elute iodide

(or thiocyanate) from the resin column. Anions that are not easily dehydrated (fluoride, chloride, bromide, sulfate, nitrate, etc.) form more hydrophilic ion pairs with the resin quaternary ammonium groups and probably are not stabilized appreciably by interaction with the hydrophobic resin environment. Therefore, this latter group of anions is more readily eluted from the column, and separations of the individual anions can be achieved.

CONCLUSIONS

A column containing an anion-exchange resin of very low capacity, together with a suitable eluent of low concentration and a conductivity detector, is capable of giving quite acceptable and quick separations of mixtures containing several anions. The great simplicity of the method makes it feasible to construct an instrument dedicated to the analysis of a single type of sample. Furthermore, a general purpose instrument could be used to determine quickly a variety of anions in different types of samples.

It is likely that the quality of separations can be improved over those reported here. For example, our apparatus has more valves and tubing than are really necessary, and this may well contribute to a certain amount of band spreading. Resins and resin columns more efficient than those used here can probably be developed, and these would give better resolution of samples containing several anions.

REFERENCES

1. Small, H.; Stevens, T. S.; Bauman, W. C. Anal. Chem. 1975, 47, 1801.
2. Sawicki, E.; Mulik, J. D.; Wittgenstein, E. In "Ion Chromatographic Analysis of Environmental Pollutants", Ann Arbor Science Publishers: Ann Arbor, Michigan, 1977.
3. Gjerde, D. T.; Fritz, J. S. J. Chromatogr. 1979, 176, 199.
4. Dasgupta, P. K.; Hanley, Jr., L. G.; West, P. W. Anal. Chem. 1978, 50, 1793.

SECTION IV.

ANION CHROMATOGRAPHY WITH LOW-CONDUCTIVITY ELUENTS II

INTRODUCTION

Ion chromatography as developed by Small, Stevens and Bauman (1) has allowed the rapid separation and quantitative determination of inorganic and organic anions. Their system, which is marketed as a commercial instrument by the Dionex Corporation, uses a separation column containing a patented anion-exchange resin. The separated anions are detected by conductance after passing through a hydrogen-form cation exchange column (called a suppressor column) to remove most of the background conductance of the eluent. In a previous paper we described a simple method called anion chromatography that separates mixtures of anions with a suppressor column (2). The absence of a suppressor column permits continuous operation of the system without any need for regeneration.

In the present work a larger number of anions have been studied and a linear correlation of log retention time with log of eluent concentration is noted. A selective method for separation of bicarbonate is described and several other examples of new separations are presented. Finally, it is shown that resin capacity and eluent concentration can be manipulated to improve significantly the sensitivity of anion chromatography.

EXPERIMENTAL

Sample solutions

Standard solutions of the potassium salts of various anions (fluoride, chloride sulfate, etc., as shown in the chromatograms) were prepared from analytical-grade reagents.

Ion-exchange resins

Two kinds of ion exchangers served as the stationary phase of the analytical column, viz. the relatively high-capacity, commercially available Vydac SC anion-exchange resin (bead size: 30-44 microns, capacity: 0.1 mequiv./g), and a low capacity anion-exchange resin prepared at this laboratory by the following method:

The copolymer used as starting material for the synthesis of the anion exchange resins was Rohm and Haas' macroreticular crosslinked poly (styrene-divinylbenzene) beads; XAD-1. This resin is highly crosslinked and has excellent chemical and mechanical stability. The beads were ground and sieved, fines were removed, and the fraction of 250-325 mesh was collected for the synthesis.

A 5 g portion of that fraction was swollen in a mixture of 10 mL chloromethylmethylether, 40 mL methylene chloride and 3 mL nitromethane. When 1.1 g of zinc chloride were added to the mixture the reaction was initiated and was maintained at room temperature for five minutes, after which

the reaction was quenched by adding water to the mixture. The beads were then filtered, washed with water and methanol and finally air dried.

The chloromethylated beads were aminated by adding 25% trimethylamine in methanol and allowing the reaction to proceed overnight. The final product was washed with 1 M HCl, 2-propanol, and water and was dried overnight at 60°C. The capacity of the XAD-1 anion-exchange resin was determined by converting a weighed amount of resin to the nitrate form and analyzing the displaced chloride by anion chromatography. The capacity was found to be 0.007 mequiv./g.

Eluents

Potassium benzoate solutions were made up in concentrations varying 1.0×10^{-3} M to 1.0×10^{-4} M and buffered to a pH of 6.25. Potassium phthalate solutions were prepared from potassium acid phthalate in concentrations ranging from 5.0×10^{-4} M to 5.0×10^{-5} M; in general the solutions were buffered at pH 6.25, but for one study the pH was 4.50 and 6.75.

Apparatus

The chromatographic system was described in an earlier publication (2). It consists of pump, sample injection

valve, resin column 3 mm i.d. x 500 mm, a conductance detector, and a recorder.

RESULTS

Comparison of eluents

In earlier work (2) resins of 0.07, 0.04 and 0.007 mequiv./g were used. Of these, the lowest capacity resin has been found to give sharper separations with improved sensitivity. In Table I are listed the adjusted retention times for 17 anions chromatographed on the 0.007 mequiv./g anion-exchange resin. The results confirm that phthalate is a more efficient eluent than benzoate because retention times with benzoate are longer than with phthalate even though the normality of the eluents is equal. In Table II the adjusted retention times for the two eluents are compared for chromatograms on Vydac resin. Again the adjusted retention times are longer with the benzoate eluent. Further comparison shows that retention times are longer on the Vydac resin than on the XAD-1 resin (0.007 mequiv./g) even though the benzoate eluent concentration used with the Vydac resin is five times that used with the XAD-1 resin.

Adjusted retention times are compared in Table III for anions on a Vydac SC resin column for phthalate eluents of two different pH values. At the lower pH much of the eluent is in the hydrogen phthalate form, while at the high pH value the divalent phthalate anion predominates. The results indicate a much more rapid elution is obtained with

Table I. Adjusted retention times of anions using monovalent and divalent eluent anions on XAD-1 0.007 mequiv./g

Anion	Adj. R. T. (min)	Adj. R. T. (min)	Adj. R. T. Benzoate
	Benzoate 2.0×10^{-4} M pH = 6.25	Phthalate 1.0×10^{-4} M pH = 6.25	Phthalate
F^-	2.28	1.40	1.63
CH_3COO^-	2.40	1.40 (neg)	1.71
$HCOO^-$	2.34	1.50 (neg)	1.56
$H_2PO_4^-$	2.20	1.74 (neg)	1.26
HCO_3^-	2.22	1.80 (neg)	1.23
Cl^-	2.30	1.46	1.58
NO_2^-	2.90	1.60	1.81
Br^-	4.16	1.88	2.21
NO_3^-	3.74	1.90	1.97
I^-	8.14	2.92	2.79
SCN^-	12.8	5.54	2.31
ClO_4^-	22.8	6.96	3.26
SO_4^{2-}	--a	7.64	
SO_3^{2-}	--a	7.74	
$C_2O_4^{2-}$	--a	8.10	
CrO_4^{2-}	--a	5.20	
$S_2O_3^{2-}$	--a	12.9	

^aVery long retention times

Table II. Adjusted retention times of anions using monovalent and divalent eluent anions on Vydac SC resin

Anion	Adj. R. T. (min)	Adj. R. T. (min)	Adj. R. T. Benzoate
	Benzoate 1.0×10^{-3} M pH = 6.25	Phthalate 5.0×10^{-4} M pH = 6.25	Phthalate
F ⁻	--a	--a	
CH ₃ COO ⁻	1.25	0	
HCOO ⁻	1.90	0	
Cl ⁻	4.72	1.00	4.72
NO ₂ ⁻	8.00	1.96	4.08
Br ⁻	20.6	4.82	4.27
NO ₃ ⁻	28.5	7.34	3.88
SO ₄ ²⁻	21.6	4.58	4.71
SO ₃ ²⁻		4.56	
Rest Monovalent	--b	--b	
Rest Divalent	--b	--b	

^aUnsure of behavior

^bVery long retention times

Table III. Adjusted retention times of anions for two different pH's of potassium phthalate on Vydac SC resin

Anion	Adj. R. T. (min)	Adj. R. T. (min)	Adj. R. T.
	5.0×10^{-4} M phthalate pH = 4.50	5.0×10^{-4} M phthalate pH = 6.75	pH = 4.50 Adj. R. T. pH = 6.75
F ⁻	-- ^a	-- ^a	
Cl ⁻	1.70	1.12	1.52
NO ₂ ⁻	3.24	2.12	1.53
Br ⁻	7.12	4.88	1.46
NO ₃ ⁻	9.42	7.74	1.23
H ₂ PO ₄ ⁻	1.72	1.00 (neg)	1.72
SO ₄ ²⁻	24.4	4.48	5.45
SO ₃ ²⁻	24.5	4.46	5.49
Rest Monovalent	-- ^b	-- ^b	
Rest Divalent	-- ^b	-- ^b	

^aUnsure of behavior

^bVery long retention times

eluent containing a divalent anion. The ratio of the adjusted retention times shows that divalent analyte anions are more affected by an eluent pH change than are monovalent analyte anions. Of course, the pH of the eluent would also affect the form of the sample anions in some cases. For example, phosphate could be taken up either as H_2PO_4^- or as HPO_4^{2-} , depending on pH. The more rapid elution of phosphate at pH 6.75 suggests that the effect of pH on the eluent is more important in this case than its effect on the form of the phosphate anion. The pH of an eluent may also affect background conductivity. The consequence of this is that phosphate appears as a negative peak when the more highly conducting pH = 6.75 eluent is used.

Effect of eluent concentration

The effect of eluent concentration on the adjusted retention time for an anion was determined by plotting log of adjusted retention time ($\log t'$) vs. log [eluent]. The plots were straight lines as may be predicted by considering the equilibrium for anions exchanging on a strong-base anion exchanger:

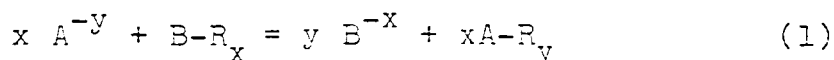

where R represents the anion exchanger, and A and B are competing anions. K, the selectivity coefficient, is

$$K_B^A = \frac{[A-R_y]^x [B]^y}{[A]^x [B-R_x]^y} \quad (2)$$

In column chromatography the sample normally uses 1% or less of the resin capacity; there, $[B-R_x]$ is essentially constant and equal to the resin capacity. In a column operation in which B is the eluent anion and A is a sample anion, the term $[B]^y$ may be written as $[\text{eluent}]^y$. The ratio of $[A-R_y]$ to $[A]$ is the A distribution ratio, D, which can be related to the adjusted retention time for the elution of A from the column. Substituting these into Eq. 2:

$$K_B^A = D^x \cdot \frac{[\text{eluent}]^y}{\text{capacity}^y} \quad (3)$$

D is related to the adjusted retention time, t' , by the equation

$$D = \frac{t'F}{W} \quad (4)$$

where W is the weight of the resin in the column and F is the flow rate of the eluent. Substituting Eq. 4 into Eq. 3:

$$K_B^A = \frac{(t'F)^x}{W^x} \cdot \frac{[\text{eluent}]^y}{\text{capacity}^y}$$

Rearranging and taking the log of both sides:

$$\begin{aligned} \log K_B^A W^x &= x \log t' + x \log F \\ &+ y \log [\text{eluent}] - y \log \text{capacity} \end{aligned}$$

or

$$\log t' = \frac{-y}{x} \log [\text{eluent}] - \text{constant} \quad (5)$$

where y is the charge of the sample anion and x is the charge of the eluent anion. The terms other than t' and $[\text{eluent}]$ are constant for each anion. The slopes of $\log t'$ vs. $\log [\text{eluent}]$ plots will vary from 0.5 to 2 depending on the charge of the anions involved.

Linear plots of $\log t'$ vs. $\log [\text{eluent}]$ were obtained experimentally in all cases. Figure 1 shows results for XAD-1 resin (0.007 mequiv./g) for varying concentrations of potassium benzoate eluent. Monovalent anions all have slopes less than the theoretical slope of -1. Phosphate has a slope of approximately -2.1, indicating that it is retained as the divalent anion. The slope of the bicarbonate is unusually low.

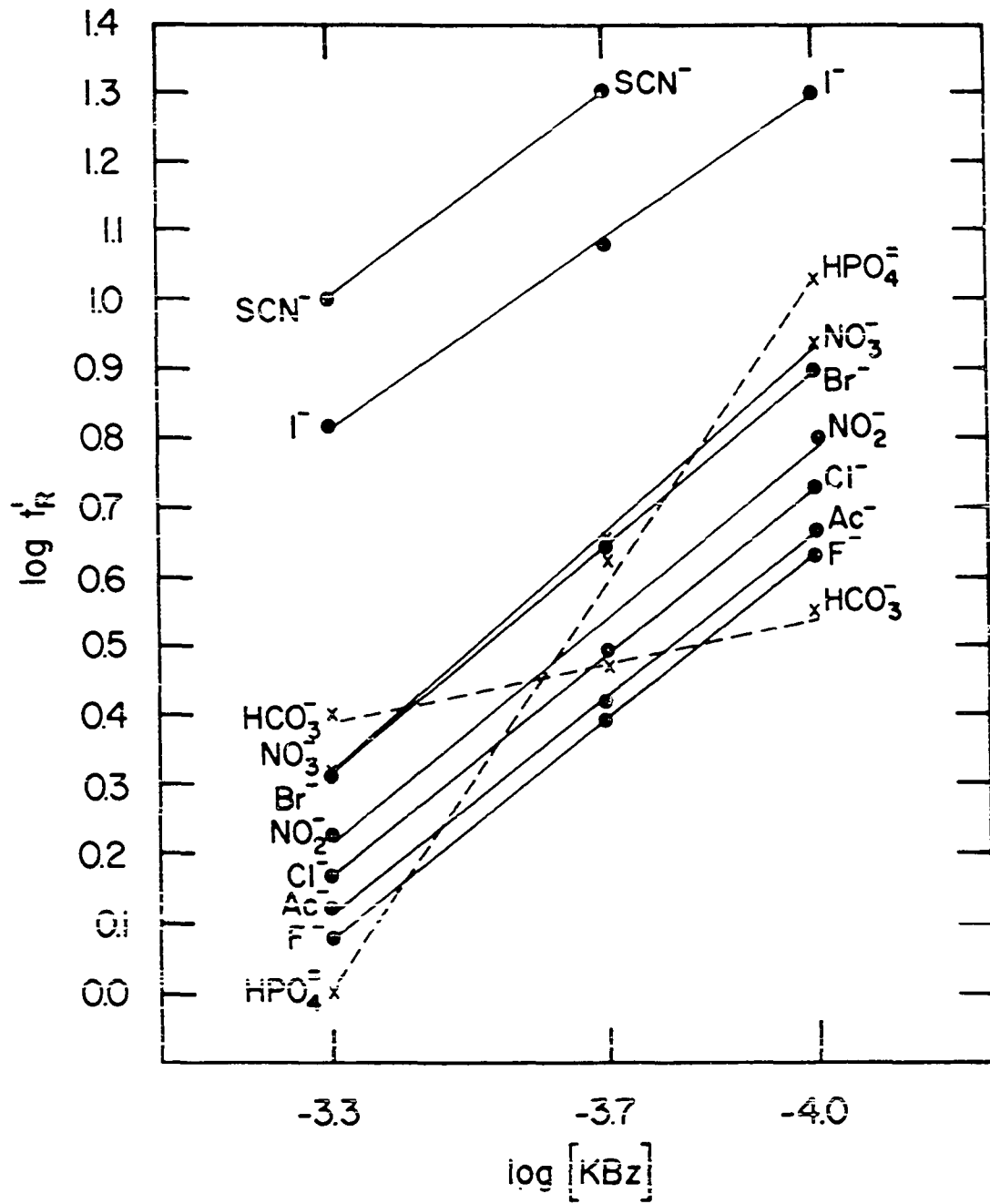

Figure 1. Adjusted retention times of anions for different concentrations of potassium benzoate using XAD-1 0.007 mequiv./g

The bicarbonate ion undoubtedly is in equilibrium with molecular carbonic acid, which may also be retained by the resin. The very low slope obtained makes it possible to adjust conditions so that bicarbonate is eluted before all other common anions.

In Figure 2 the behavior of several anions is plotted as a function of benzoate concentration for Vydac SC resin. The slopes are even lower than with the XAD-1 resin in Figure 1. There is a distinct difference between the adjusted retention times of formate and acetate, and also between these anions and chloride.

Adjusted retention times are plotted as a function of potassium phthalate concentration for XAD-1 resin (Figure 3) and for Vydac SC resin (Figure 4). Assuming the eluent anion is entirely present as phthalate (-2), the theoretical slope should be -1 for each divalent anion and -0.5 for each monovalent anion. In Figure 3 the slopes for sulfite, sulfate and oxalate are very close to the theoretical, but the slopes of most of the monovalent anions are higher than predicted. The greater slope of the divalent anions with respect to the monovalent is very convenient. By adjusting the eluent concentration, elution of sulfate, sulfite or oxalate can be slowed down for better separation from monovalent anions, or elution can be speeded up for a more rapid determination of any of these divalent anions. The results with Vydac resin

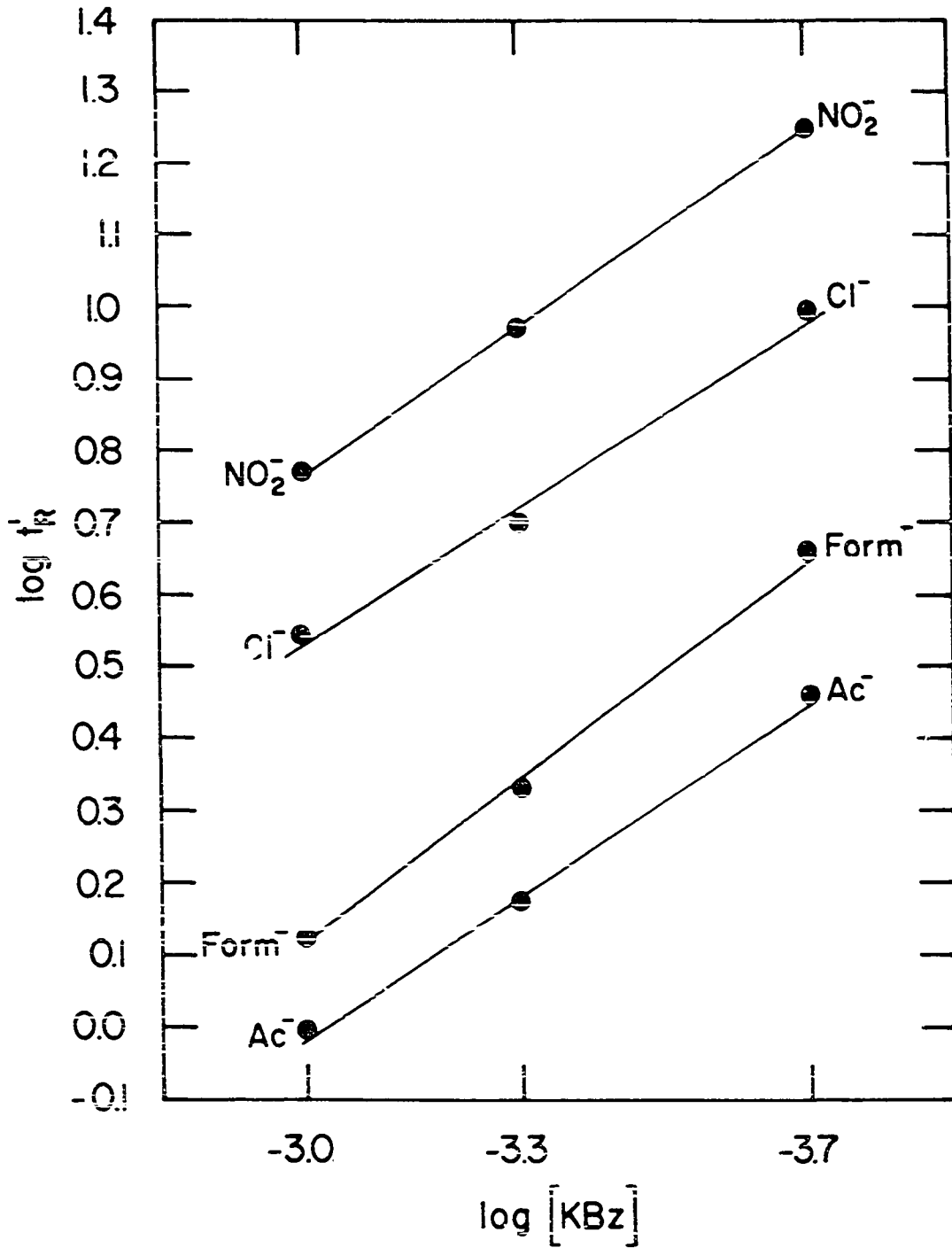

Figure 2. Adjusted retention times of anions for different concentrations of potassium benzoate using Vydac SC anion exchanger

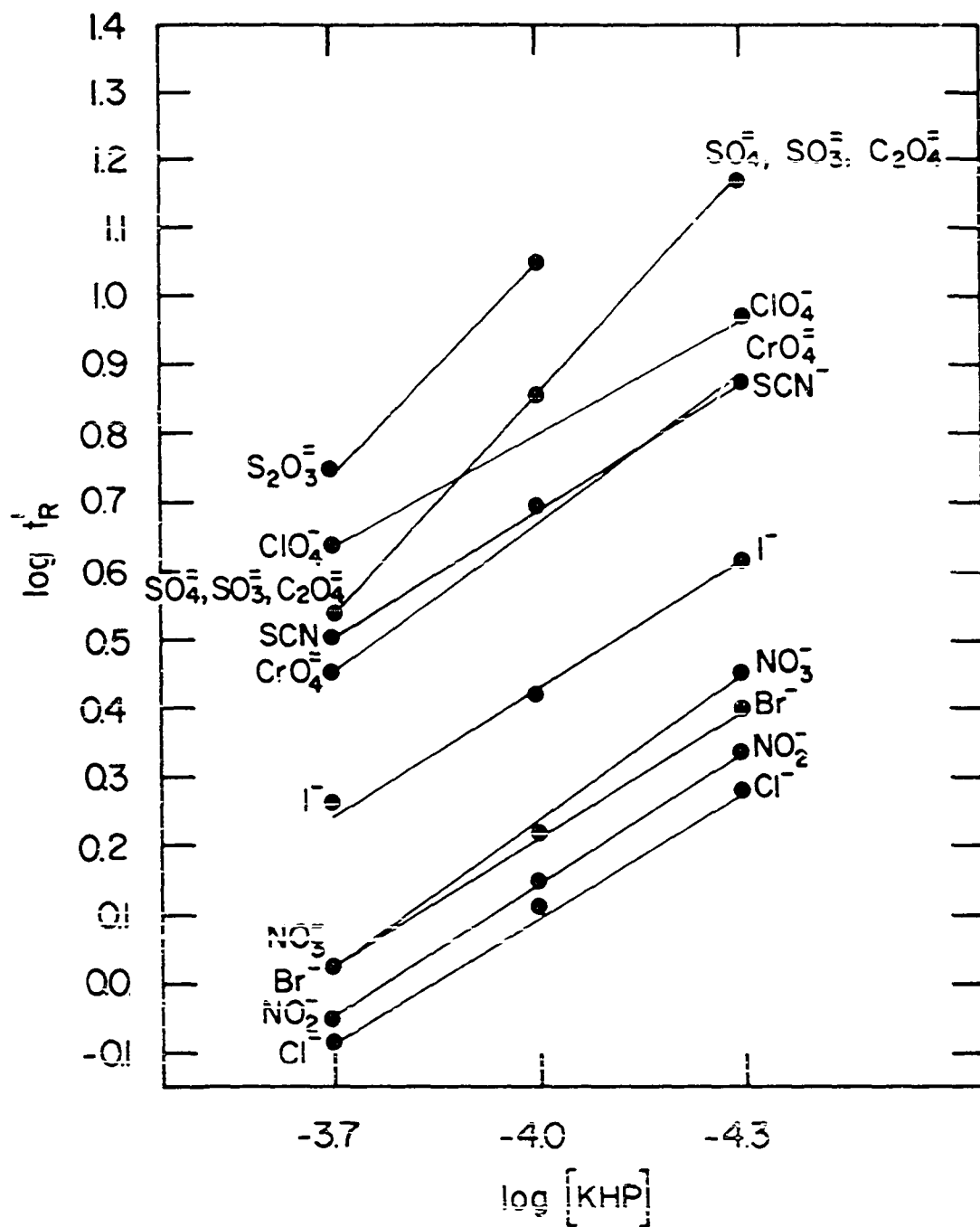

Figure 3. Adjusted retention times of anions for different concentrations of potassium phthalate using XAD-1 0.007 mequiv./g

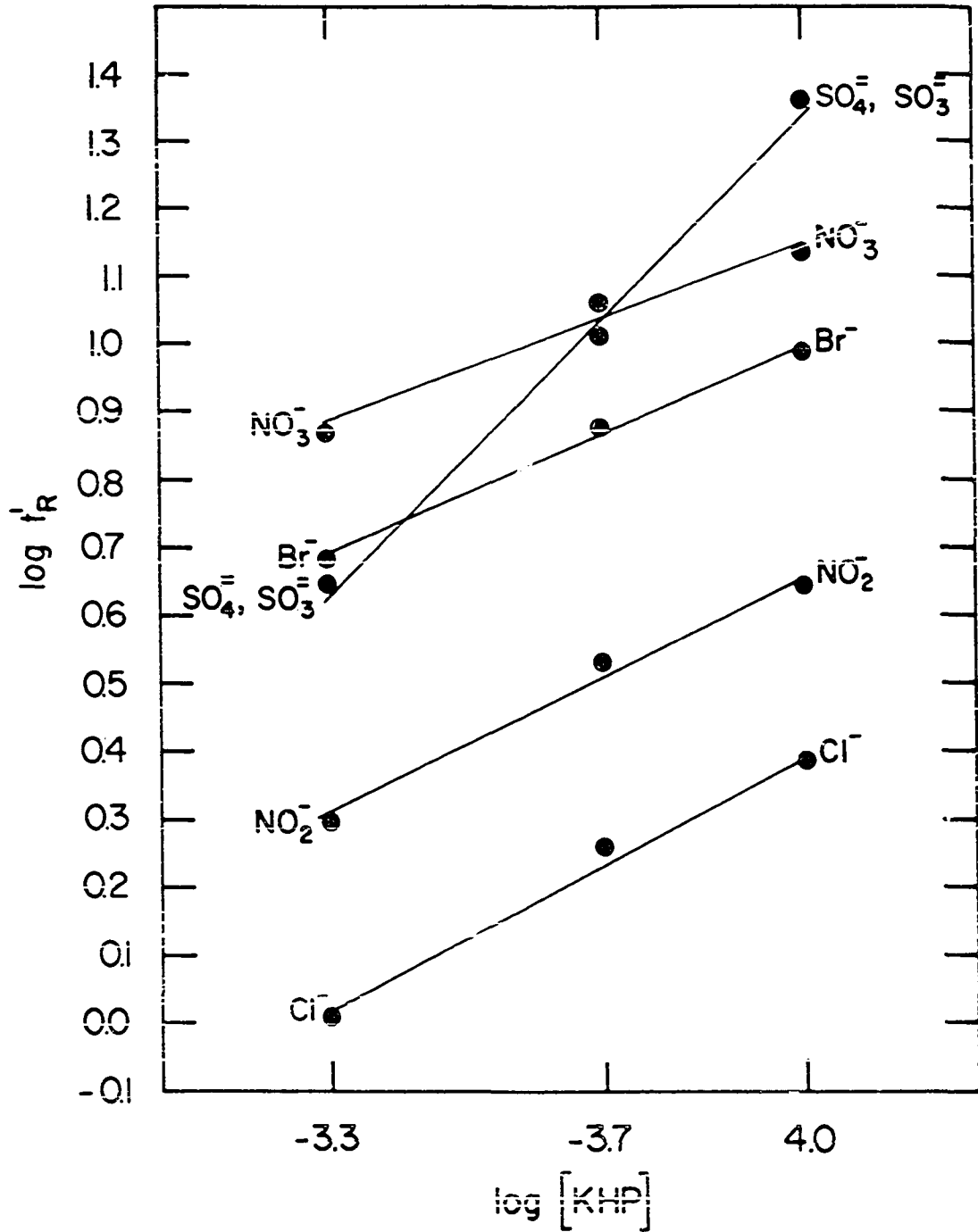

Figure 4. Adjusted retention times of anions for different concentrations of potassium phthalate using Vydac SC anion exchanger

show a rather good agreement with the predicted slopes except for chloride.

New separations

By using approximately 1.0×10^{-4} M benzoate as the eluent, bicarbonate is eluted before any of the other anions studied (see Figure 1). Bicarbonate in a tap water sample was determined. Figure 5 shows a small bicarbonate peak in a diluted tap water sample; the peak is larger after addition of some bicarbonate to the sample. Using several standard additions of bicarbonate, a linear plot, shown in Figure 6, was obtained. Extrapolation of the plot indicated a bicarbonate concentration of 52 ppm in the original water sample. The optimum pH of the eluent is approximately 5.7. A pH of 6.25 works well, but a higher pH would result in broadening of the bicarbonate peak. Even though the sample also contained a large amount of sulfate, this did not interfere with later injections. The sulfate is a late-eluting anion under these conditions, and will only be seen as a slight shift in the baseline.

In the same water sample, chloride and sulfate were each determined by anion chromatography; calcium plus magnesium were determined by titration with EDTA, and sodium and potassium were measured by atomic spectroscopy. The following cation material balance was obtained: calcium plus magnesium, 2.96 mequiv./L; sodium plus potassium, 0.89

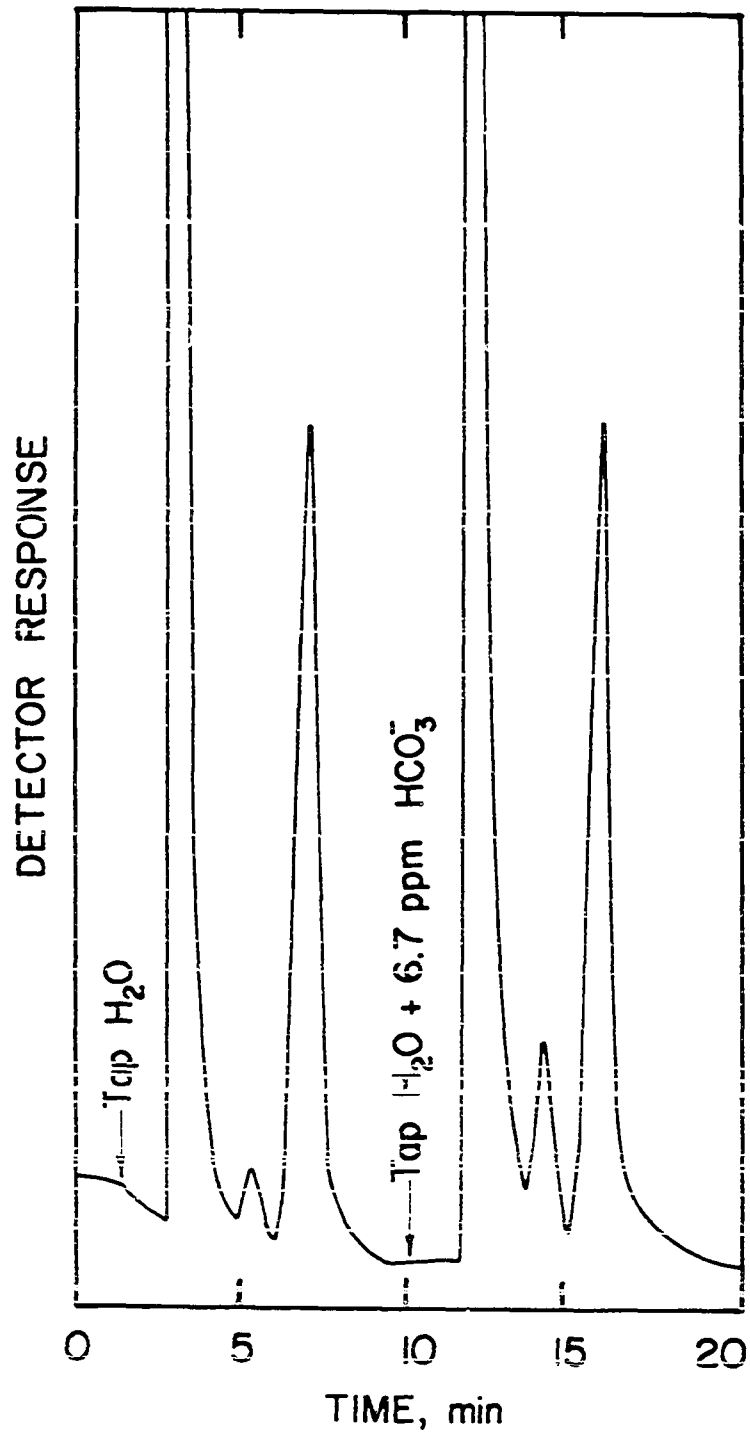

Figure 5. Separation of total carbonate from all other anions in Iowa State University tap water using 1×10^{-4} M potassium benzoate, pH = 6.25 on XAD-1 0.007 mequiv./g

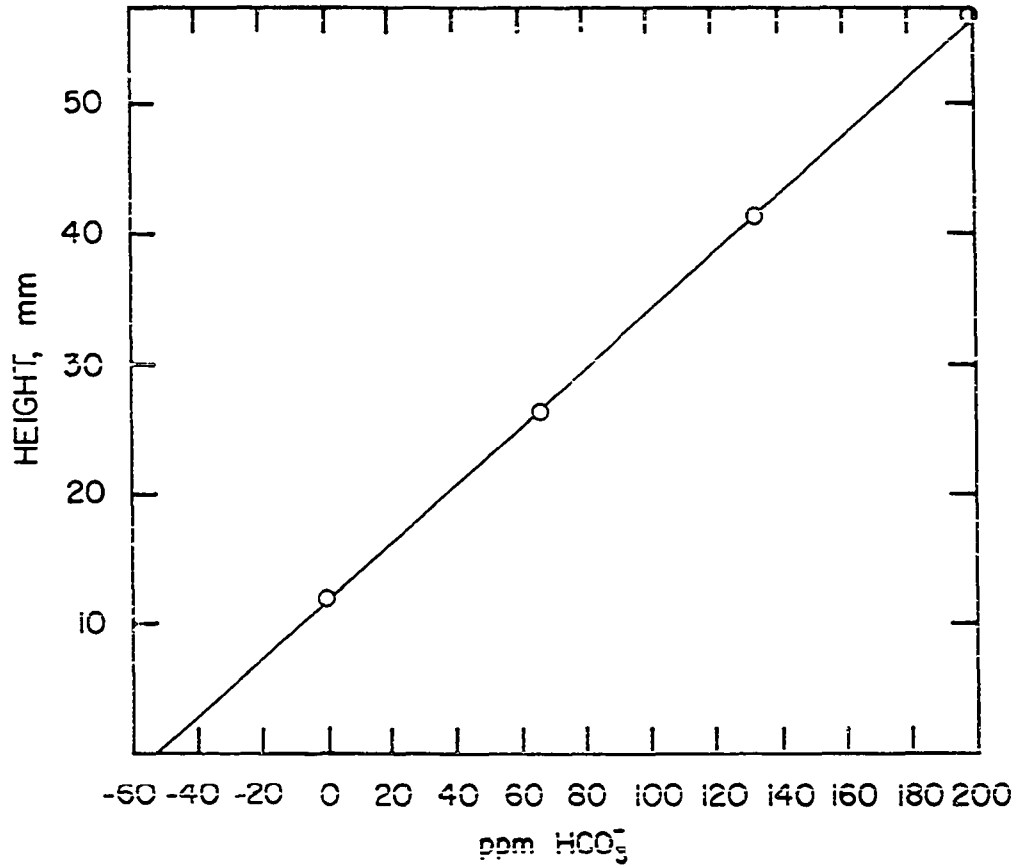

Figure 6. Standard addition curve for determining bicarbonate in Iowa State University tap water

mequiv./L; total cations, 3.85 mequiv./L. Anions: sulfate, 1.87 mequiv./L; chloride, 1.02 mequiv./L; bicarbonate, 0.85 mequiv./L; total anions, 3.74 mequiv./L. The material balance is considered to be satisfactory in that some minor constituents (fluoride, for example) were not measured.

Phosphate has now been included in the list of anions that can be determined successfully by anion chromatography. Figure 7 shows the chromatogram of a leading cola drink, diluted with distilled water. The bicarbonate peak, resulting from carbon dioxide in the original sample, decreased as the sample stood, and some CO_2 was lost. The carbon dioxide was at least partially converted to bicarbonate upon injection by the buffering action of the eluent. It seems likely that carbon dioxide in various aqueous samples can be determined quantitatively by first buffering the sample to convert the CO_2 to bicarbonate, then determining the bicarbonate by anion chromatography.

Figure 7 shows that the initial phosphate peak increases in height when phosphate is added to the sample. Again using the standard addition method, a linear plot was obtained with an extrapolated intercept that indicated 610 ppm of HPO_4^{2-} in the original cola sample.

Formate and acetate are difficult to separate from each other by ion chromatography. Figure 8 shows a good

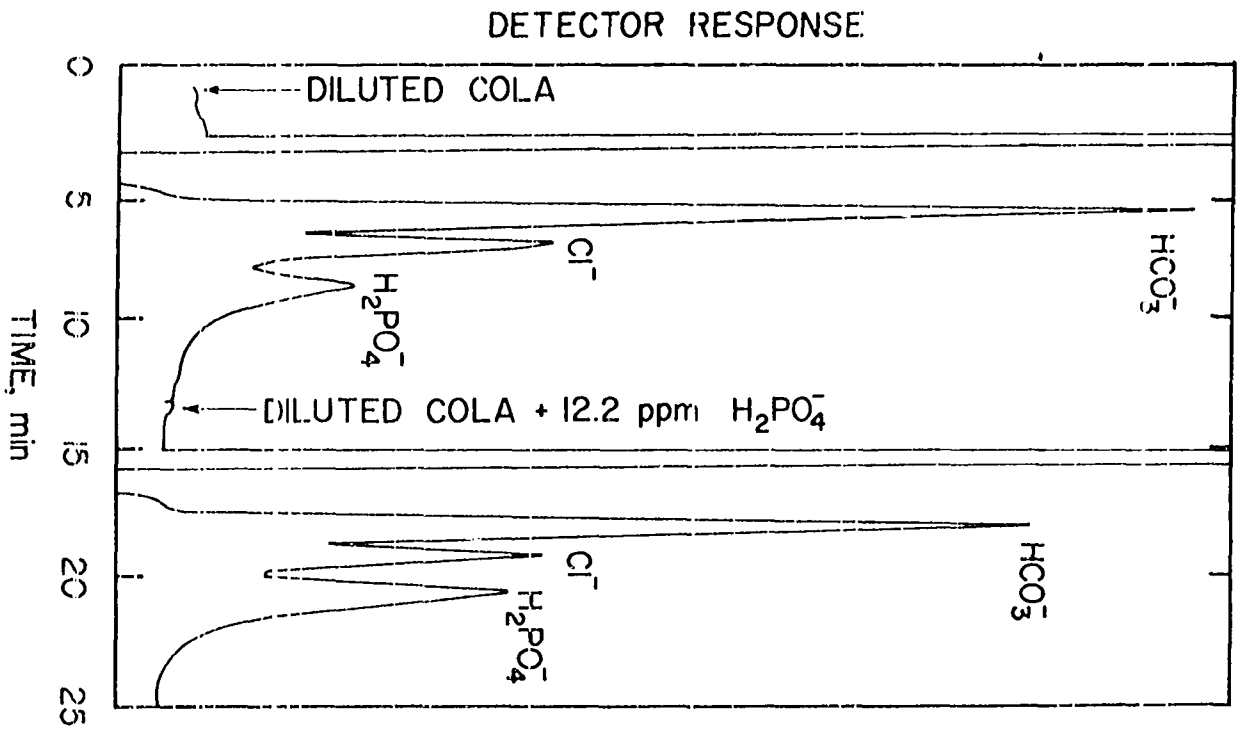

Figure 7. Separation of phosphate from all other anions in diluted cola drink using 1×10^{-4} M potassium benzoate, pH = 6.25 on RAD-1 0.007 mequiv./g

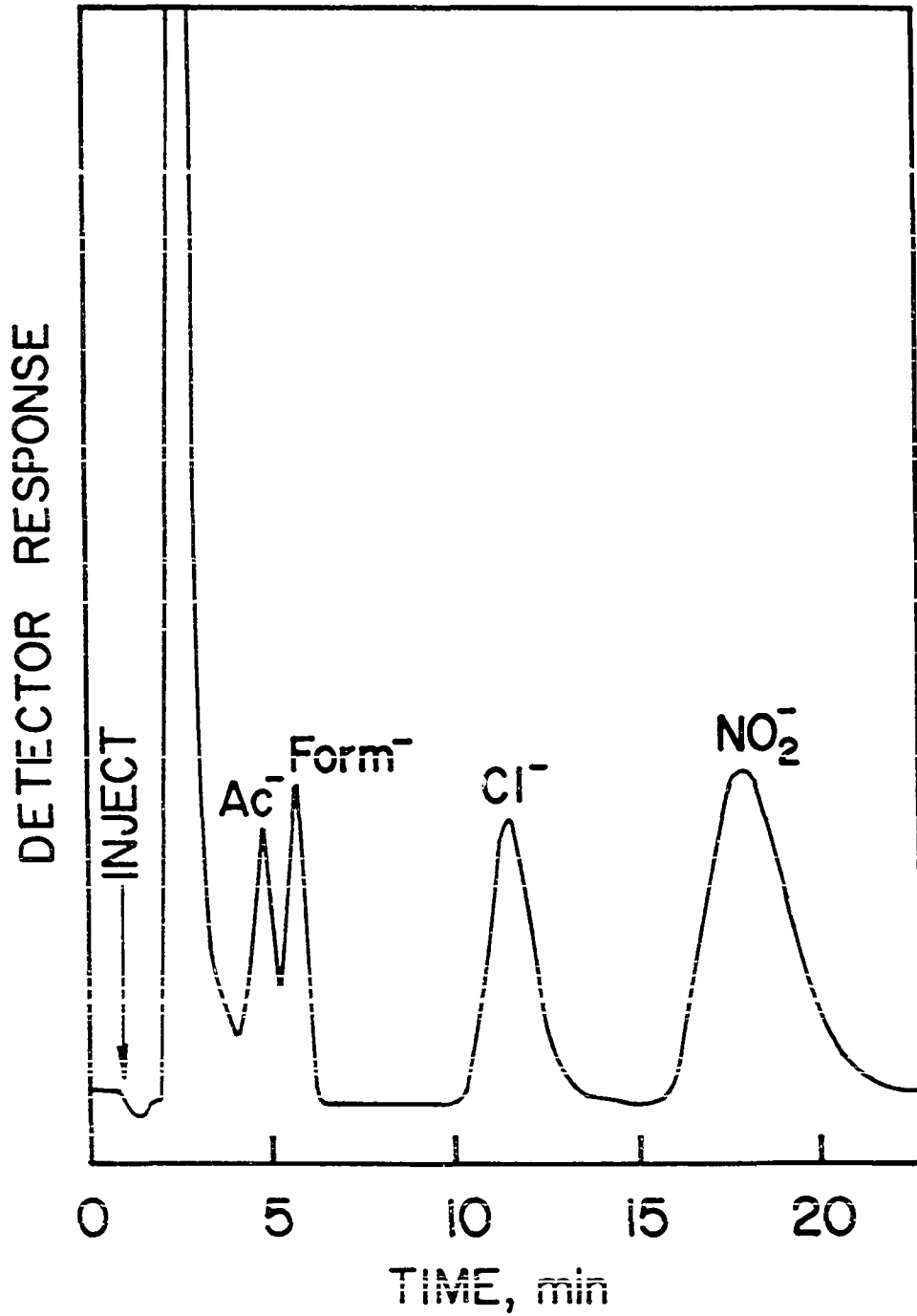

Figure 8. Separation of 27.1 ppm acetate, 6.8 ppm formate, 5.1 ppm chloride and 15.8 ppm nitrite using 5×10^{-4} M potassium benzoate, pH = 6.25 on Vydac SC anion exchange resin

separation of these anions from each other and from chloride and nitrite on a column containing Vydac resin.

Increasing the sensitivity of separations

With phthalate eluent, it was observed that many anions could be eluted in a reasonable time even with eluents as dilute as 5.0×10^{-5} M and lower provided a low-capacity resin was used. With such dilute eluents, many of the anion peaks at first were excessively broad and showed fronting. However, when the concentration of the sample anions was reduced, good peaks were again obtained.

The conductance of these eluents is lower than those used earlier ($1.0-$ to 5.0×10^{-4} M) and permits use of a more sensitive setting on the detector. Thus, by using a low capacity resin and a more dilute eluent, anions can be successfully chromatographed at lower concentration levels. By increasing the detector sensitivity setting, the concentrations of the anions can be decreased and a good separation can still be obtained. Figure 9 shows the chromatogram for separation of chloride, bromide and iodide at the ppb concentration level.

It will be seen that resin capacity and eluent concentration are powerful parameters that can be varied in tandem to increase the sensitivity of anion chromatography.

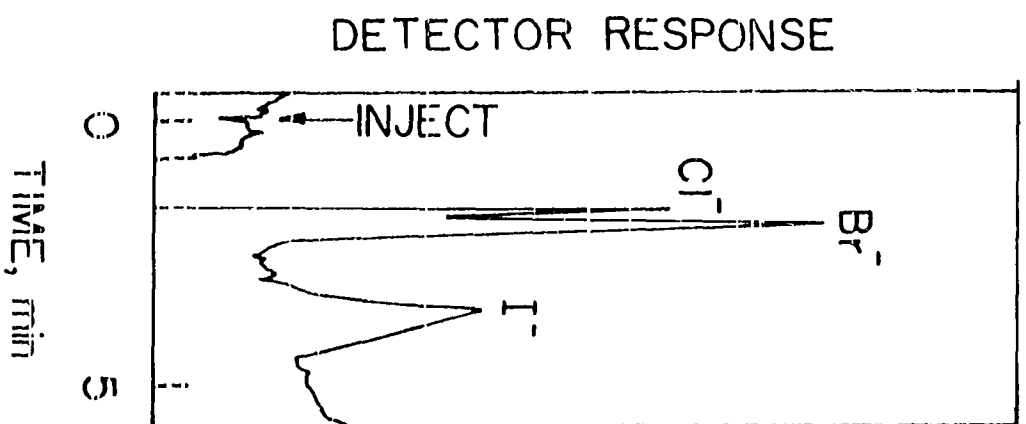

Figure 9. Separation of 20 ppb chloride, 65 ppb bromide and 96 ppb iodide using 5×10^{-5} M potassium phthalate, pH = 6.25 on XAD-1 0.007 mequiv./g

Experiments are underway with resins of still lower capacity that may result in still lower detection limits.

DISCUSSION

If XAD-1 resin is assumed to be primarily polystyrene, it can be calculated that anion-exchange resin with a capacity of only 0.007 mequiv./g contains less than one quaternary ammonium functional group per 1000 benzene rings. This raises the question of whether the functional groups are distributed rather evenly throughout the resin or are clustered together near the more accessible surfaces. The latter case is suggested by the fact that phthalate, a -2 anion, is a more powerful eluent than benzoate, a -1 anion. Further support for this case is given by the difference in slopes of -1 and -2 anions in Figure 3. These data suggest that sulfate, for example, behaves as a -2 anion and that each sulfate is associated in some way with two quaternary ammonium groups. The possibility that sulfate is associated with less than two resin functional groups and that electroneutrality is maintained by uptake of a positive counter ion was rejected after equilibrating a solution of potassium sulfate with some resin. Subsequent analysis showed no uptake of potassium by the resin.

Although columns containing Vydac resin give very good separations in many cases, we found a slow degradation of this resin which gradually shortens elution times for the

various anions. In one case this gradual degradation caused sulfate to run into the bromide peak, although a good separation of the two had been obtained earlier with fresh resin. It was also observed that no fluoride peak can be obtained using Vydac resin.

The order of elution of anions (see Table I) is similar to that reported for conventional anion exchange resins and also is consistent with the hydration energies and polarizabilities. On XAD resins of very low capacity, fluoride and chloride prefer the dilute aqueous phase over the resin and are poorly resolved. Bromide and iodide, with their smaller hydration energies and higher polarizabilities, elute much later and are well resolved. Nitrite is somewhat displaced in the order of elution. It should elute before chloride if hydration and polarizability were the sole consideration, but nitrite is a polyatomic ion stabilized by resonance structures and cannot be directly compared with halide ions. Thiocyanate elutes still later, after iodide, because of its lower hydration energy and high polarizability.

REFERENCES

1. Small, H.; Stevens, T. S.; Bauman, W. C. Anal. Chem. 1975, 47, 1801.
2. Gjerde, D. T.; Fritz, J. S.; Schmuckler, G. J. Chromatogr. 1980, 187, 35.

SECTION V.

EFFECT OF CAPACITY ON THE BEHAVIOR
OF LOW-CAPACITY MACRORETICULAR ANION-EXCHANGE RESINS

INTRODUCTION

Conventional ion exchange of inorganic ions has been done mostly with high capacity ion-exchange resins. There have been only a few reports that describe the preparation and characterization of partially sulfonated resins (1-5). Some have made use of these low-capacity sulfonated ion exchangers and demonstrated excellent separations (6-11).

The field of anion exchange has been more neglected. Gjerde and Fritz (12) studied strong-base macroporous anion exchangers ranging 0.04 to 1.46 mequiv./g. Distribution ratios of anions decreased with decreasing capacity and selectivity coefficients were essentially constant for the anions studied. Low-capacity anion exchangers have proved to be extremely useful for the separation and automatic detection of anion mixtures (10,12-15). Low-capacity resins need only a low eluent concentration and this has allowed the use of a conductivity detector after eluent pretreatment with a suppressor column (10). Gjerde, Fritz, and Schmuckler (14,15) showed that when a carefully chosen eluent is used with a low-capacity resin, a conductivity detector may be coupled directly with the separator column for the automatic detection of anions. In this work, the effect of capacity on the behavior of these low-capacity macroporous anion exchangers is studied. Selectivity coefficients and

distribution data are determined for 15 different anions on resin capacities ranging from 0.0016 to 0.024 mequiv./g.

EXPERIMENTAL

Resin synthesis

The material used for the synthesis of the anion-exchange resins was macroporous XAD-1 poly (styrene-divinylbenzene) copolymer obtained from Rohm and Haas (Philadelphia, PA, U.S.A.). XAD-1 has a surface area of $100 \text{ m}^2/\text{g}$ and an average pore diameter of 205 \AA . The 100-200 mesh spherical resin was chloromethylated using a procedure described by Goldstein and Schmuckler (16). A 4 g portion of the resin was swollen with 4 mL of chloromethylmethylether. With stirring, 100 mL of dichloromethane, 3 mL of nitromethane and 1 g of zinc chloride were added. Resin capacities were controlled by varying the time of chloromethylation from 3 minutes to 45 minutes. Reactions were performed at room temperature. After the appropriate time, the reactions were quenched by adding water. The resins were then cleaned, aminated and dried in the usual manner (15). The capacities of the anion exchangers were determined by converting a weighed amount of resin to the nitrate form, washing with water and then displacing the nitrate with excess sulfate. The displaced nitrate was determined by ion chromatography, and the capacities were calculated.

Selectivity coefficients

Selectivity coefficients of anions as a function of resin capacity were calculated from retention volumes measured from a column of the resin and other column and eluent data. Amounts of anions injected on to the column generally corresponded to much less than 1% of the total column capacity, although, they took up as much as 2% of the lowest capacity column. The liquid chromatograph used to make the measurements was described in a previous publication (14). The detector was a Wescan Instrument's model 213 Conductivity Meter (Santa Clara, CA, U.S.A.). A 500 mm x 3.8 mm i.d. column was used for all experiments which held approximately 1 g of resin. Eluent flow rate was 2.30 mL/min. The mobile phase volume was measured by injecting water and noting the volume to the negative water peak. Eluents were 1.00×10^{-4} M potassium phthalate and 1.00×10^{-4} M potassium benzoate. The eluents were adjusted to pH 6.75 so that they were completely ionized.

RESULTS AND DISCUSSION

The effect of resin capacity on the behavior of monovalent anions was predicted by equations shown in previous work (12). In this work, divalent anions are also studied and more general equations are needed. Consider the equilibrium for anions exchanging on a strong-base anion exchanger:

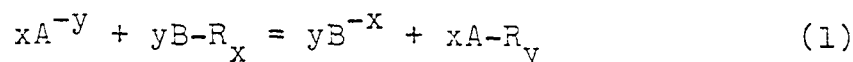

where R represents the anion exchanger, and A and B are competing anions. K, the selectivity coefficient, is

$$K_B^A = \frac{[A-R_y]^x [B]^y}{[A]^x [B-R_x]^y} \quad (2a)$$

When the anionic charges, x and y, are equal then:

$$K_B^A = \frac{[A-R_y] [B]}{[A] [B-R_x]} \quad (2b)$$

In column chromatography, the sample normally uses 1% or less of the resin capacity; therefore, $[B-R_x]$ is essentially constant and equal to the resin capacity. In a column operation in which B is the eluent anion and A is a sample anion, the term $[B]^y$ may be written as $[\text{eluent}]^y$.

The ratio of $[A-R_y]$ to $[A]$ is an A distribution ratio, D, which can be related to the adjusted retention time for the elution of A from the column. Substituting these into Eq. 2:

$$K_B^A = D^x \cdot \frac{[\text{eluent}]^y}{\text{capacity}^y} \quad (3)$$

D is related to the adjusted retention time, t' , by the equation

$$D = \frac{t' F}{W} \quad (4)$$

where W is the weight of the resin in the column, and F is the flow rate of the mobile phase. Substituting Eq. 4 into Eq. 3:

$$K_B^A = \frac{(t'F)^x}{W^x} \cdot \frac{[\text{eluent}]^y}{\text{capacity}^y} \quad (5)$$

Our results, calculated using Eq. 5, are shown in Tables I and II. The results indicate that selectivity coefficients remain quite constant for most anions. Some of the selectivity coefficients are a bit low for the lowest capacity resin; however, it should be remembered relative errors are greater when small retention volumes are measured, and this may or may not be a real trend.

Table I. Selectivity coefficients, K_{B}^A , for XAD-1 low-capacity anion exchangers; A = sample anion; B = eluent anion, phthalate

Anion	Capacity XAD-1 (mequiv./g)							
	0.0016	0.0024	0.0035	0.0071	0.010	0.015	0.017	0.024
Cl ⁻	--- ^a	--- ^a	0.038	0.081	0.084	0.077	0.072	0.076
NO ₂ ⁻	--- ^a	--- ^a	0.038	0.084	0.098	0.11	0.096	0.090
Br ⁻	--- ^a	--- ^a	0.074	0.15	0.15	0.18	0.16	0.17
NO ₃ ⁻	--- ^a	--- ^a	0.087	0.18	0.21	0.21	0.21	0.22
I ⁻	--- ^a	0.21	0.53	1.1	2.0		2.6	3.7
SCN ⁻	0.28	0.67	1.8	4.0	6.2	8.3	--- ^b	--- ^b
ClO ₄ ⁻	1.1	1.8	3.6	7.2	--- ^b	--- ^b	--- ^b	--- ^b
CrO ₄ ²⁻	0.16	0.22	0.24	0.23	0.23	--- ^b	--- ^b	--- ^b
SO ₃ ²⁻	--- ^a	0.15	0.21	0.21	0.21	0.20	0.19	0.17
SO ₄ ²⁻	--- ^a	0.16	0.21	0.21	0.20	0.20	0.18	0.17
S ₂ O ₃ ²⁻	0.38	0.44	0.50	0.47	0.43	--- ^b	--- ^b	--- ^b

^aPeaks are too early to measure

^bPeaks are too late to measure

Table II. Selectivity coefficients, K_B^A , for low-capacity XAD-1 anion exchangers; A = sample anion; B = eluent anion, benzoate

Anion	Capacity XAD-1 (mequiv./g)							
	0.0016	0.0024	0.0035	0.0071	0.010	0.015	0.017	0.024
IO_3^-	--- ^a	--- ^a	0.076	0.086	0.080	0.072	0.074	0.062
F^-	--- ^a	--- ^a	0.070	0.076	0.075	0.067	0.067	0.050
HCOO^-	--- ^a	--- ^a	0.070	0.080	0.073	0.069	0.071	0.064
CH_3COO^-	--- ^a	--- ^a	0.080	0.089	0.086	0.076	0.078	0.067
Cl^-	--- ^a	0.10	0.12	0.13	0.12	0.098	0.092	0.078
NO_2^-	--- ^a	0.11	0.12	0.14	0.13	0.11	0.11	0.091
Br^-	--- ^a	0.16	0.17	0.20	0.19	0.16	0.16	0.14
NO_3^-	--- ^a	0.15	0.18	0.21	0.20	0.18	0.17	0.17
I^-	0.27	0.50	0.63	0.80	--- ^b	--- ^b	--- ^b	--- ^b

^aPeaks are too late to measure

^bPeaks are too early to measure

There are three exceptions to the constancy of selectivity coefficients: iodide, thiocyanate and perchlorate. It is unclear why these particular anions behave differently from other anions. They are all large, monovalent and normally late eluting, but they have differing chemical characteristics.

Since selectivity coefficients for most anions are constant, it is useful to rearrange Eq. 3:

$$D^x = \frac{K_B^A \text{ capacity}^y}{[\text{eluent}]^y} \quad (6)$$

When Eq. 6 is arranged in this way, it is clear that distribution ratios (and retention times) of sample anions will decrease with decreasing capacity. This has already been shown with higher capacity anion-exchange resins (12). Figures 1 and 2 show this is also the case with these anion exchangers. The slopes of iodide, thiocyanate and perchlorate are higher than other monovalent anions as expected from the selectivity data. These results explain the fact that XAD-1 anion-exchange resin of 0.007 mequiv./g capacity is a much better resin than 0.07 and 0.04 mequiv./g for the separation of mixtures containing iodide and thiocyanate (14).

To see if the macroporous anion-exchanger substrate had any effect on the retention of anions, an XAD-4 resin

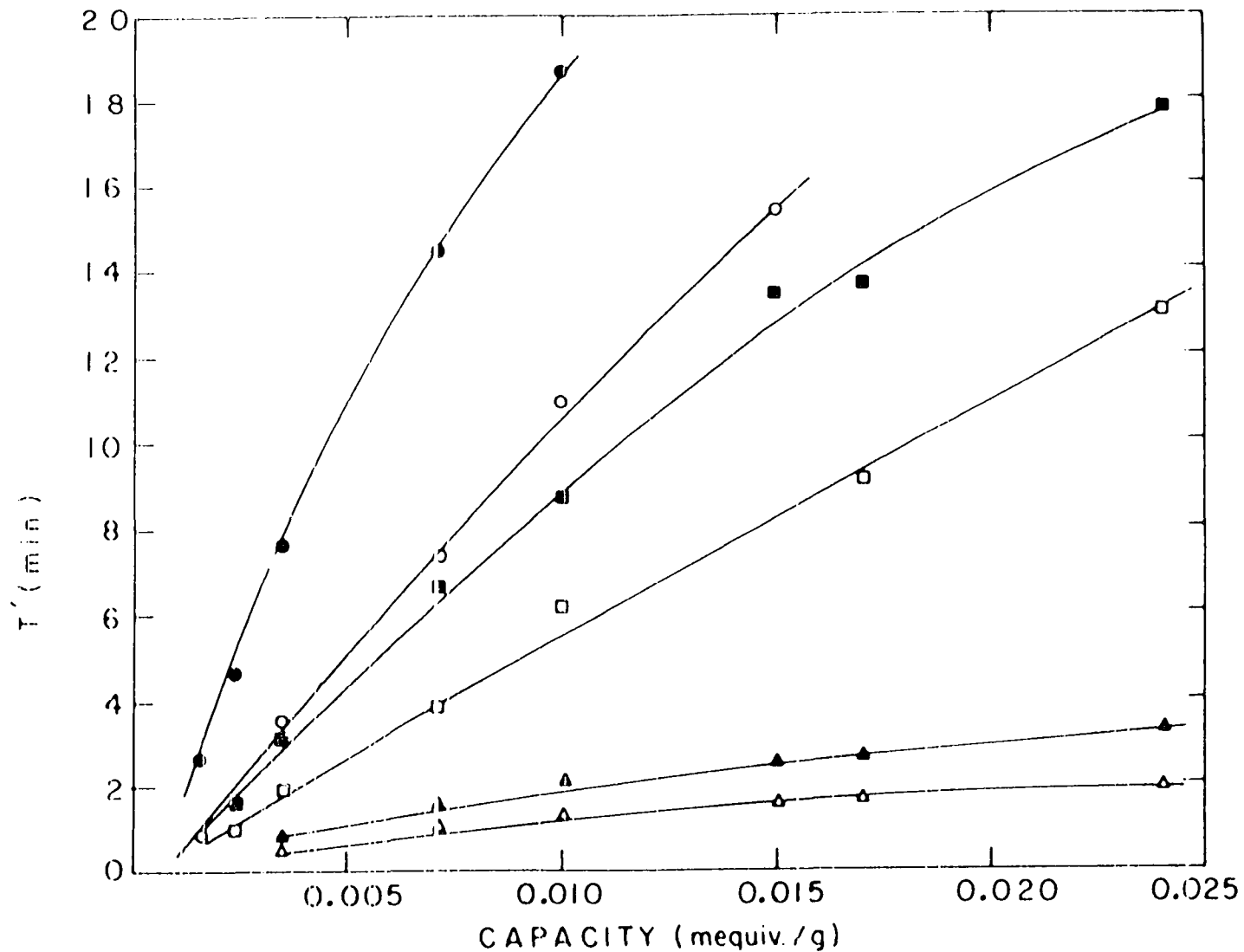

Figure 1. Adjusted retention times of representative anions for resins of different capacity. Eluent: 1.00×10^{-4} M potassium phthalate, pH = 6.75. Δ , chloride; \blacktriangle , nitrate; \square , iodide; \blacksquare , sulfate; \circ , thiocyanate; \bullet , thiosulfate

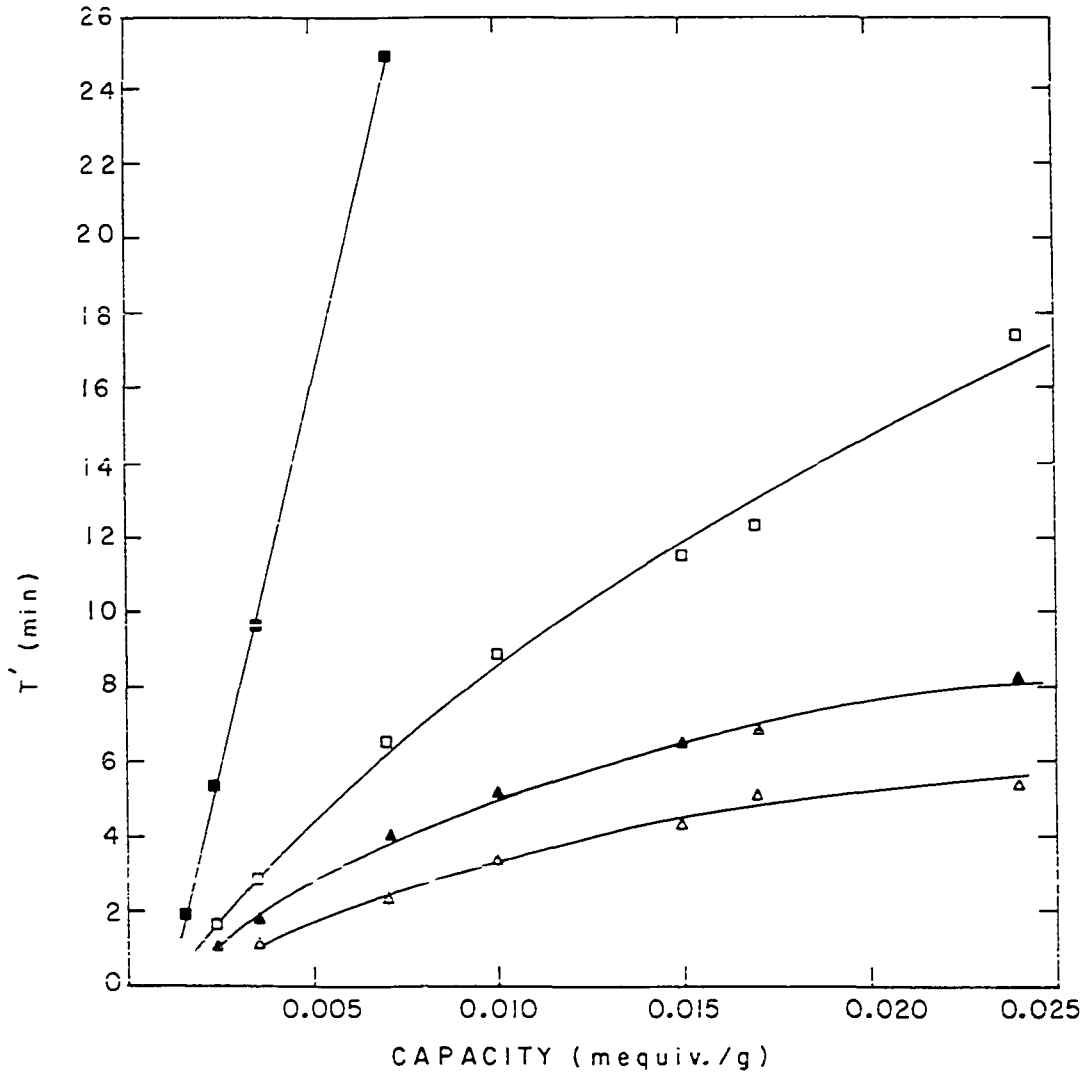

Figure 2. Adjusted retention times of representative anions for resins of different capacity. Eluent: 1.00×10^{-4} M potassium benzoate, pH = 6.75. Δ , fluoride; \blacktriangle , chloride; \square , nitrate; \blacksquare , iodide

of zero ion-exchange capacity was tested. XAD-4 was used because it has ~ 8 times the surface area of XAD-1, and any retention effects would be enhanced. When standard 10^{-4} M eluent solutions of potassium benzoate and potassium phthalate were tried, all anions tested came off with the solvent front. However, when the eluent was changed to water, the chromatogram shown in Figure 3 was obtained. The phenomenon is quite interesting because, potentially, an analytical method employing a water eluent and conductivity detector is quite sensitive. However, the peaks are broad and the system is of no practical value at this time.

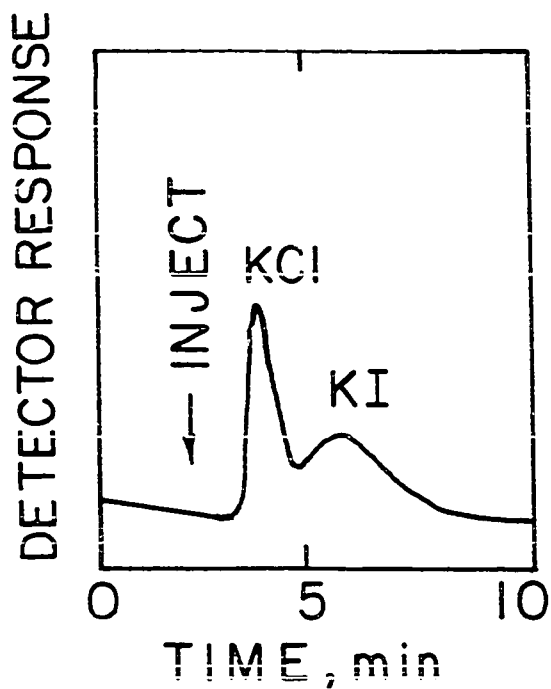

Figure 3. Separation of 3 ppm chloride and 5 ppm iodide as potassium salts; Column: 500 mm x 3 mm i.d.; Resin: XAD-4, 200-250 mesh; Eluent: water; Flow: 2.0 mL/min

CONCLUSIONS

The selectivity coefficients reported here allow the prediction of distribution ratios and elution volumes of anions in column chromatography. The constancy of selectivity coefficients for most anions make these predictions especially convenient.

REFERENCES

1. Boyd, G. E.; Soldano, B. A.; Bonner, O. D. J. Phys. Chem. 1954, 58, 456.
2. Lindenbaum, S.; Jumper, C. F.; Boyd, G. E. J. Phys. Chem. 1959, 63, 1924.
3. Reichenberg, D. in "Ion Exchange"; Marinsky, J. A., Ed.; Marcel Dekker: New York, 1966; Vol. 1, Chapter 7.
4. Freeman, D. A.; Aiyar, A. S. Anal. Chem. 1967, 39, 1141.
5. Fritz, J. S.; Story, J. N. J. Chromatogr. 1974, 90, 267.
6. Skafi, M.; Lieser, K. H. Z. Anal. Chem. 1970, 249, 182.
7. Skafi, M.; Lieser, K. H. Z. Anal. Chem. 1970, 250, 306.
8. Skafi, M.; Lieser, K. H. Z. Anal. Chem. 1970, 251, 177.
9. Fritz, J. S.; Story, J. N. Anal. Chem. 1974, 46, 825.
10. Small, H.; Stevens, T. S.; Bauman, W. C. Anal. Chem. 1975, 47, 1801.
11. Fritz, J. S.; Gjerde, D. T.; Becker, R. M. Anal. Chem. accepted for publication.
12. Gjerde, D. T.; Fritz, J. S. J. Chromatogr. 1979, 176, 199.
13. Gjerde, D. T.; Fritz, J. S. J. Chromatogr. 1980, 188, 391.
14. Gjerde, D. T.; Fritz, J. S.; Schmuckler, G. J. Chromatogr. 1979, 186, 509.
15. Gjerde, D. T.; Schmuckler, G.; Fritz, J. S. J. Chromatogr. 1980, 187, 35.
16. Goldstein, S.; Schmuckler, G. Ion Exch. Membr. 1973, 1, 135.

SECTION VI.

CATION CHROMATOGRAPHY USING A CONDUCTIVITY DETECTOR

INTRODUCTION

Ion chromatography as developed by Small et al. (1) has allowed the rapid separation and determination of anions; their methods have also been applied successfully for analysis of alkali metal and alkaline earth cations and for some amine cations. Their method uses a separating column filled with an ion-exchange resin of low capacity. The separated ions are detected by a conductance detector after passage through a second column called a "suppressor column". For cation separations, the suppressor column is filled with a high-capacity anion-exchange resin in the hydroxide form. The function of this second column is to neutralize the acidic eluent and thus to reduce the background conductance. The suppressor column requires periodic regeneration and also limits the metal cations which can be present in the sample to those that are not precipitated by the hydroxide ion in the anion-exchange resin.

In previous papers (2,3) we described a simple method called anion chromatography which permits separation and conductivity detection of anions without use of a suppressor column. Anion chromatography is based on two principal innovations: (a) use of a special anion-exchange resin of very low capacity and (b) the adoption of an eluent which

is quite dilute and has a low background conductivity. The separated anions are easily seen as positive conductivity peaks relative to the background.

It seemed feasible to develop a successful system for separation of inorganic and amine cations that is analogous to our method for anion chromatography. Thus, cation separations would be on a cation-exchange column of very low capacity with a very dilute eluent solution, and the separated cations would be detected by a conductivity detector placed immediately after the separation column. A successful system for cation analysis is now reported. The best eluent is a dilute solution of either nitric acid or of an ethylenediammonium salt. Excellent and rapid separations were obtained for magnesium(II), calcium(II), strontium(II), and barium(II) and also for mixtures containing lithium, sodium, ammonium, potassium, rubidium, and cesium cations. A novel feature of the method is that the separated cations give peaks in the negative direction because the equivalent conductance of each separated cation is less than that of the eluent cation.

EXPERIMENTAL

Ion-exchange resins

XAD-1 resin from Rohm and Haas (Philadelphia, PA., U.S.A.) was sulfonated by chlorosulfonic acid in methylene chloride or by concentrated sulfuric acid. Although resins of several capacities were prepared, only that with an exchange capacity of 0.01 mequiv./g was actually tested.

Vydac SC cation-exchange resin was obtained from the Separations Group, Hesperia CA, U.S.A. The bead size is 30 to 44 μm , and the exchange capacity is 0.1 mequiv./g.

The poly (styrene-divinylbenzene) cation-exchange resin used in this work was prepared from a copolymer obtained from the Benson Co. (Reno, NV, U.S.A.), their BN-X4 poly (styrene-divinylbenzene) beads, 20 μm diameter. The starting resin is spherical and normally is used for gel permeation chromatography. The resin was sulfonated according to Small (4) by adding 5 mL of concentrated sulfuric acid to 2 g of resin and stirring for 15 minutes at a temperature of 100°C. Then the reaction was quenched with water and the resin washed with water and with 2-propanol. After drying overnight at 60°C., the capacity was determined by converting a weighed amount to the lithium form, washing, and then displacing the lithium(I) with an excess of a potassium salt. The displaced

lithium(I) was analyzed by cation chromatography and the capacity was calculated. Two batches of resin were made, producing resins with capacities of 0.017 and 0.021 mequiv./g.

Eluents

Nitric acid eluents were prepared by dilution of Ultrex nitric acid (J. T. Baker, Phillipsburg, NJ, U.S.A.). Hydrochloric acid was not used as an eluent because of its corroding effect on stainless steel.

Ethylenediammonium dinitrate solutions were prepared by dilution of ethylenediamine and adjusting the solution to the desired pH with nitric acid.

Sample solutions

Standard solutions of the alkali metal cations were made by direct weighing and dilution of the chloride salts. Alkaline earth solutions were prepared and standardized by titration with EDTA.

Apparatus

The chromatographic system was described in an earlier publication (2). It consisted of a pump, sample injection valve, resin column, conductance detector, and a recorder with variable input voltage. The detector was a Wescan Instruments model 213 Conductivity Meter, (Santa Clara, CA,

U.S.A.). A 100 μ L sample loop was used. The integrator was a Spectra-Physics System I.

RESULTS AND DISCUSSION

Choice of experimental conditions

Because of the success of anion-exchange resins made from Rohm and Haas XAD-1 macroreticular poly (styrene-divinylbenzene), we first attempted to use a sulfonated XAD-1 resin for cation-exchange separations. However, with this resin, eluents containing benzyltriethylammonium chloride, pyridinium chloride, quinolinium chloride and nitric acid each failed to give any separation of mixtures of alkali metal and alkaline earth ions.

Next, a column packed with Vydac SC, a resin 30 to 44 μm in diameter with 0.1 mequiv./g exchange capacity, was tried with various eluents. With 0.0015 M nitric acid eluent, an excellent separation of alkali metal cations was obtained on a 30 cm Vydac column (see Figure 1).

Further experiments showed that metal cations could be separated on columns containing lightly sulfonated polystyrene resin beads. The best resin was obtained by sulfonating 20 μm spherical polystyrene-4% divinylbenzene under mild conditions. One batch of resin had a capacity of 0.017 mequiv./g and the other a capacity of 0.021 mequiv./g. These capacities were a bit too high for the best separation of alkali metal ions with nitric acid eluent. Attempts to prepare a satisfactory resin of lower capacity were not immediately successful. The problem was solved,

Figure 1. Separation of 1.0 ppm lithium, 2.75 ppm sodium, 2.88 ppm potassium, 5.16 ppm rubidium, and 9.43 ppm cesium; Resin: Vydac SC cation exchanger; Eluent: 1.5×10^{-3} M nitric acid; Column: 340 mm x 2 mm i.d.; Flow: 0.72 mL/min

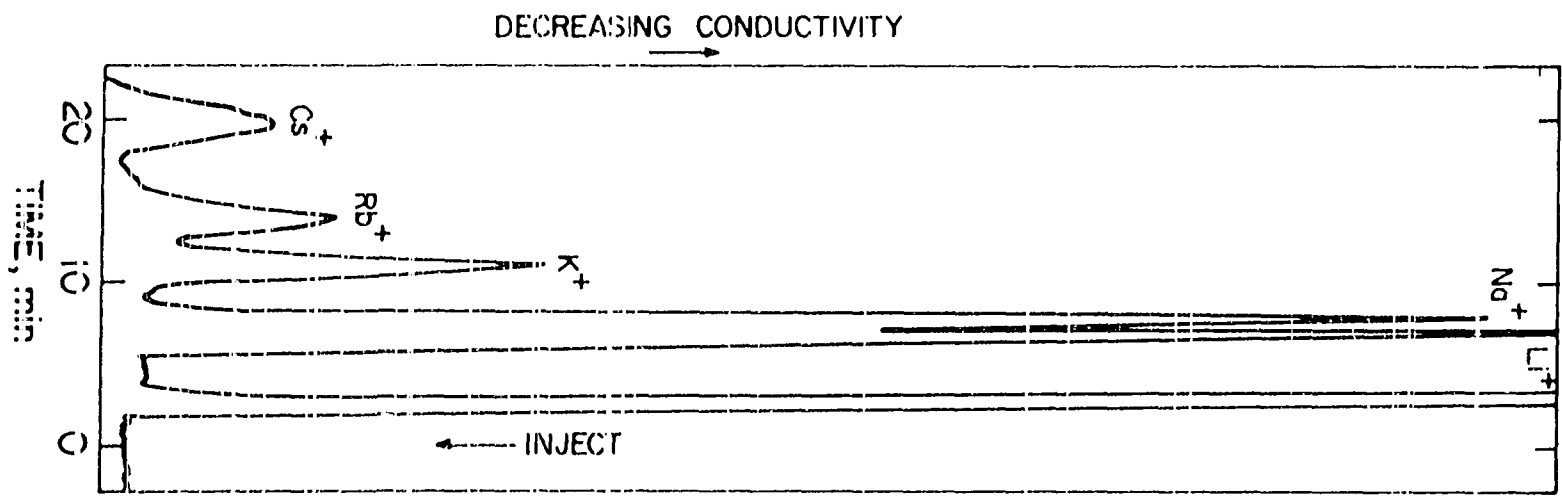

however, by packing the chromatographic column with a 3:2 blend of unsulfonated poly (styrene-divinylbenzene) resin and ~ 0.02 mequiv./g cation-exchange resin. An excellent separation of the five alkali metal ions plus the ammonium ion was obtained (see Figure 2). Blending of the resins increased the HETP slightly but had no great effect on column efficiency.

Although eluents containing nitric acid (or another acid) are suitable for separation of the alkali metal ions, these eluents are ineffective for separation of divalent metal ions, such as the alkaline earths. Eluents containing a m-phenylenediamine salt have been recommended for separation of the alkaline earths (5). We obtained fairly good separations with m-phenylenediamine eluents but encountered some difficulty from the oxidation products of the eluent that are sorbed on the top of the column and are quite difficult to remove. Eluents containing a salt of ethylenediamine gave even better separations and did not discolor the column. An excellent separation of magnesium (II), calcium(II), strontium(II), and barium(II) on 0.017 mequiv./g BN-X⁴ using an ethylenediammonium eluent is shown in Figure 3. Separations were also obtained under similar conditions on a Vydac SC column, but the resolution was somewhat inferior to that obtained on the sulfonated-polystyrene column.

Figure 2. Separation of 0.087 ppm lithium, 0.26 ppm sodium, 0.22 ppm ammonium, 0.31 ppm potassium, 0.47 ppm rubidium, and 0.86 ppm cesium; Resin: BN-X4 blend, 3:2 ratio neutral: 0.017 mequiv./g; Eluent: 1.25×10^{-3} M nitric acid; Column: 300 mm x 2 mm i.d.; Flow: 1.0 mL/min

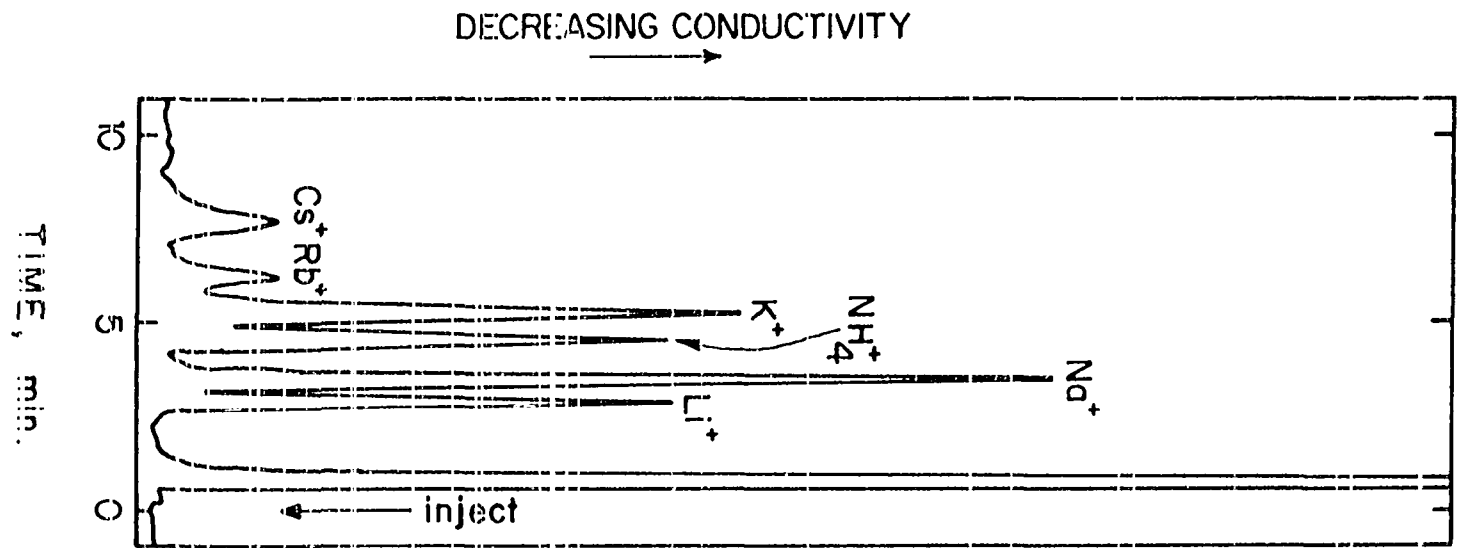
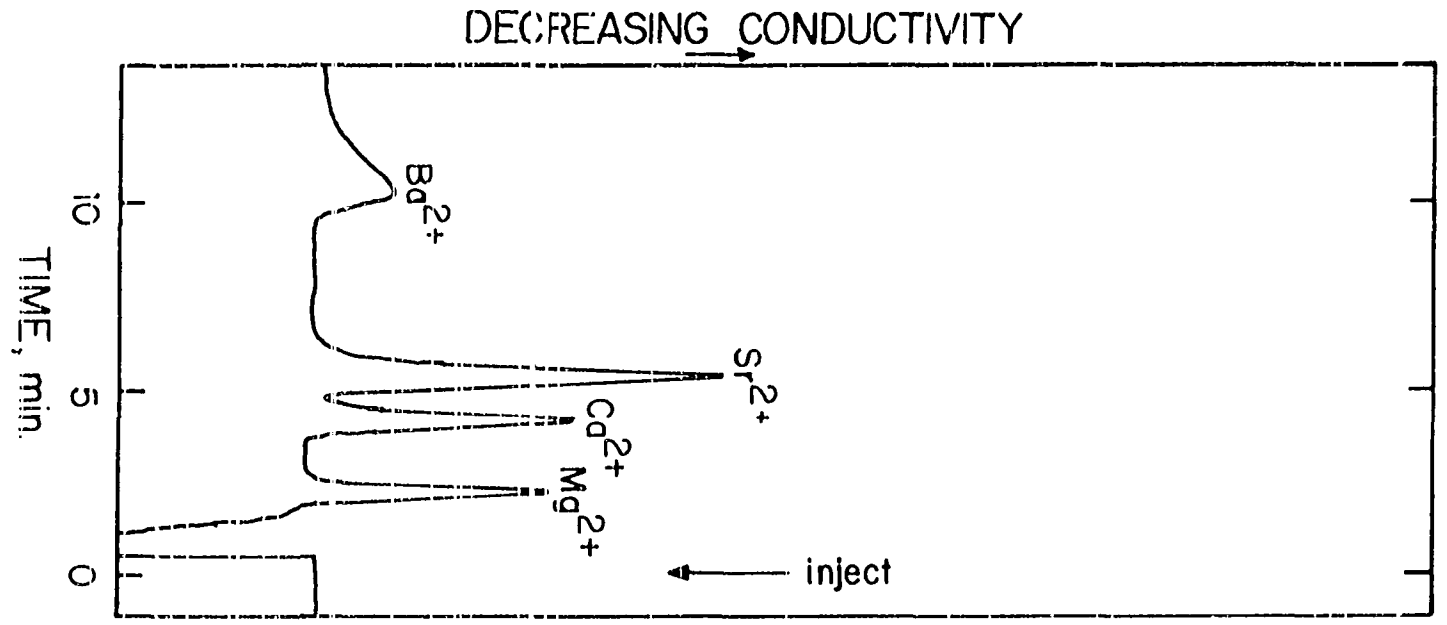

Figure 3. Separation of 4.1 ppm magnesium, 17.1 ppm calcium, 50.8 ppm strontium and 40.9 ppm barium; Resin: BN-X4 0.017 mequiv./g; Eluent: 1.0×10^{-3} M ethylenediammonium dinitrate, pH = 6.1; Column: 340 mm x 2 mm i.d.; Flow: 1.0 mL/m



Attempts to separate ammonium and alkali metal cations with ethylenediammonium eluents proved futile, even when the eluents were diluted considerably. Therefore, an acidic eluent such as nitric acid should be used for separation of lithium(I), sodium(I), potassium(I), etc., and an eluent containing the ethylenediammonium ion should be chosen for separation of divalent metal cations. Vydac SC and sulfonated poly (styrene-divinylbenzene) resins are satisfactory for chromatographic separation of cation mixtures, but the latter resin is generally more efficient and is recommended for most separations.

Explanation of chromatographic peaks

In the separations shown (Figures 1-3), the peaks of the separated sample cations are actually in the negative direction (decreasing conductance), although in the figures the chromatograms have been inverted so that peaks appear to be in the normal, positive direction. The reason for the negative peaks is that the equivalent conductance of each of the alkali metal cations is less than that of the hydrogen ion of the eluent. Similarly, the equivalent conductance of each divalent metal ion is less than that of the ethylenediammonium eluent cation. This behavior can be explained.

In cation chromatography, when a sample containing a series of solute cations (s^+ , s'^+ , $s''+$, etc.,) and a common

solute anion (s-) is injected, the cations are taken up by the ion exchanger, and an equivalent amount of the eluent cation (e+) goes in solution. The cation (e+) and the anion (s-) resulting from the sample injection pass as a plug through the column and the detector. If the total ionic concentration of the sample plug is greater than that of the eluent, a positive "pseudo" peak will result; if it is lower than that of the eluent a negative "pseudo" peak will result.

After the sample plug has passed, the baseline is quickly restored to that obtained with the eluent alone. However, the solute cations gradually move down the column, pushed by the mass-action effect of the eluent cation on the ion-exchange equilibrium. The total cation concentration in solution is fixed by the eluent cation concentration because a solute cation can only enter the solution phase by uptake of an equivalent number of eluent cations. The solute cations have a lower equivalent conductance than the eluent cation, hence the conductance will be lower when a solute band is passing through the detector and some of the eluent cations are replaced by lower-conducting solute cations.

This behavior can be explained mathematically. The specific conductance, k (mho/cm), of salts measured

by a conductivity detector is given by Eq. 1:

$$k = \frac{(\Lambda_{s+} + \Lambda_{s-})C_s + (\Lambda_{e+} + \Lambda_{e-})C_e}{1000} \quad (1)$$

where Λ (mho-cm²/equiv.) is the ion equivalent conductance, and C_s and C_e are the concentrations (equiv./L) of the solute and eluent ions, respectively. The + or - denotes the charge of the ion. The right-hand term is divided by 1000 because there are 1000 cm³ in 1L.

The change in conductance when a sample solute band passes through the detector results from replacement of some of the eluent cations by solute cations, although the total ion concentration remains constant.

$$C_s + C_e = C_{total} \quad (2)$$

where C_{total} is the total cation concentration. The eluent anion is the counter ion for both the sample and eluent cations.

The background conductance, k' , (when $C_s = 0$) is given by the following equation:

$$k' = \frac{(\Lambda_{e+} + \Lambda_{e-})C_{total}}{1000} \quad (3)$$

The conductance, k'' , when a solute band is eluted is given by Eq. 4:

$$k'' = \frac{(\Lambda_{e+} + \Lambda_{e-})C_{\text{total}}}{1000} + \frac{(\Lambda_{s+} - \Lambda_{e+})C_s}{1000} \quad (4)$$

The difference in conductance is obtained by subtracting Eq. 3 from Eq. 4:

$$\Delta k = k'' - k' = \frac{(\Lambda_{s+} - \Lambda_{e+})C_s}{1000} \quad (5)$$

In the systems used, the equivalent conductance of the eluent cation (H^+ or EnH_2^{++}) is significantly greater than that of a solute cation (Na^+ , Ca^{++} , etc.). Thus, Eq. 5 shows that the conductance decreases when a sample band is eluted and that the decrease is proportional to the concentration of the sample solute, C_s .

Applications

Reagent grade magnesium chloride was dissolved in distilled water, injected onto a Vydac SC ion-exchange column, and eluted with 0.0015 M nitric acid. The chromatogram, shown in Figure 4, gave peaks for sodium and potassium which corresponded to 0.003% and 0.002%, respectively. No peak was obtained for magnesium, which

Figure 4. Separation of sodium and potassium impurities in reagent grade magnesium chloride; Resin: Vydac SC cation exchanger; Eluent: 1.5×10^{-3} M nitric acid; Column: 340 mm x 2 mm i.d.; Flow: 0.72 mL/min

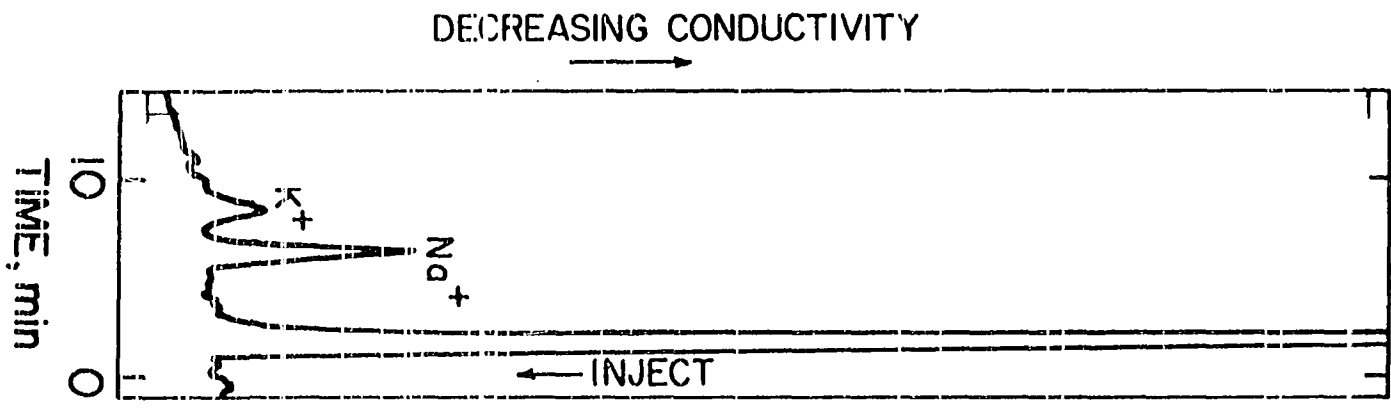

apparently was held strongly by the column. Although interesting, a method for regenerating the column would be needed before this could become a practical analytical method.

Tap water was analyzed for alkali metal ions using a column containing a 3:2 blend of unsulfonated resin and ~ 0.02 mequiv./g poly (styrene-divinylbenzene) cation exchange resin. The eluent was 0.00125 M nitric acid. Based on linear standard addition plots the chromatogram in Figure 5 yielded concentrations of 14.3 ppm sodium, 0.45 ppm ammonium, and 1.55 ppm potassium in the original water. When elution with the nitric acid eluent was continued, a long-drawn-out peak of magnesium and calcium appears. However, after elution of the alkali metal ions was complete, it was found that calcium and magnesium could be easily removed by injecting a $100 \text{ }\mu\text{L}$ portion of 0.2 M nitric acid. After this injection, the baseline returns to normal rather quickly and the column is ready for the next water sample. Even with the extra injection of nitric acid to recondition the column, an analysis of water for sodium, ammonium and potassium requires only 10 minutes.

Tap water can also be analyzed quickly and easily for magnesium and calcium. Figure 6 shows a chromatogram of diluted tap water obtained with a column of 0.017 mequiv./g

Figure 5. Separation of sodium, ammonium and potassium in diluted tap water; Resin: BN-X4 blend, 3:2 ratio neutral: 0.017 mequiv./g; Eluent: 1.25×10^{-3} M nitric acid; Column: 340 mm x 2 mm i.d.; Flow: 1.0 mL/min

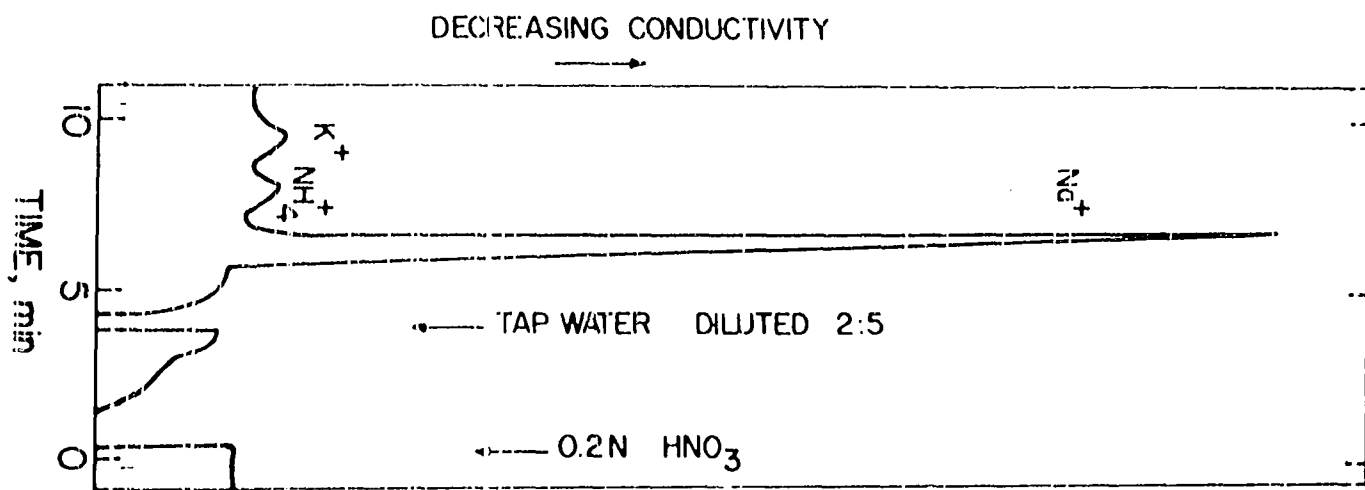
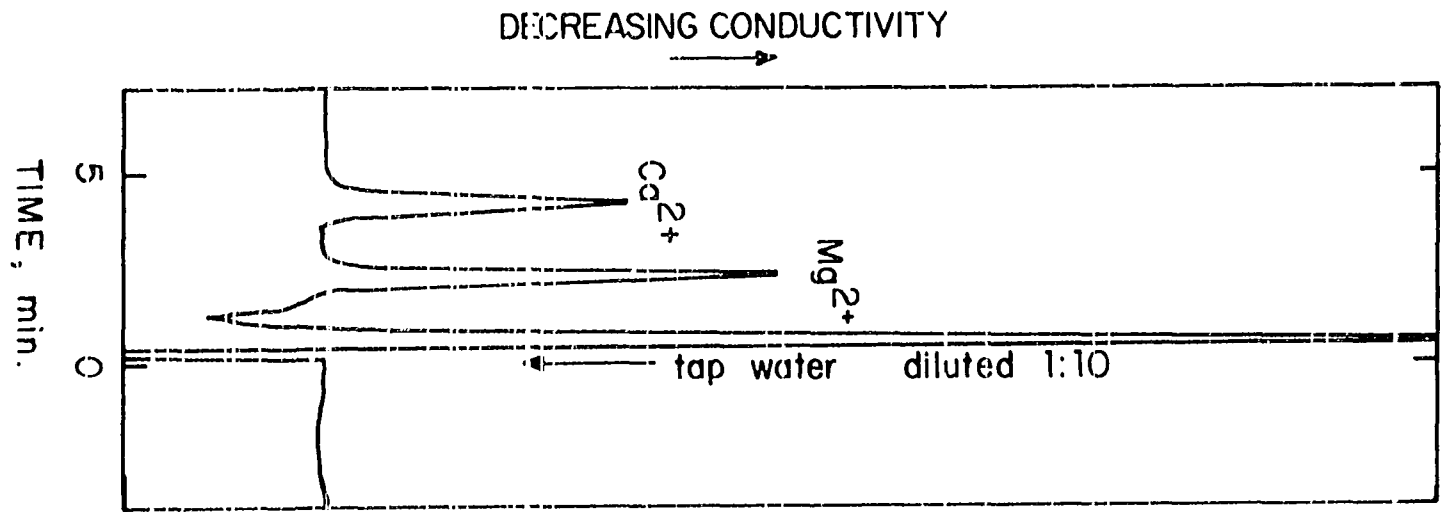

Figure 6. Separation of magnesium and calcium in diluted tap water; Resin: BN-X4 0.017 mequiv./g; Eluent: 1.0×10^{-3} M ethylenediammonium dinitrate, pH = 6.1; Column: 340 mm x 2 mm i.d.; Flow: 1.0 mL/min



poly (styrene-divinylbenzene) cation-exchange resin and 0.001 M ethylenediammonium dinitrate eluent at pH 6.1. Analysis by standard addition gave concentrations of 14.4 ppm magnesium and 45.0 ppm calcium in the undiluted water.

The effect of eluent pH on the determination of magnesium and calcium was studied. At pH values between 3.6 and 5.7 an additional peak was obtained. This is believed to be a carbonic acid peak which comes from reaction of the bicarbonate ion in the water with the acidic eluent. The retention time of this peak changes with pH. In the pH range 4.0 to 5.7 it may interfere with the magnesium-calcium separation, but between pH 3.6 and 4.0, the bicarbonate peak comes before the magnesium peak and causes no difficulty. In the latter pH range, it may be possible to estimate the bicarbonate present in the original water sample from the peak height.

Equation 5 predicts a detector response proportional to sample solute concentration, and this was confirmed in practice. Linear plots of peak height vs. concentration were always obtained except in the region where the sample solute concentration approaches that of the eluent. In this region, the peaks tend either to front or tail, and the calibration plot is not quite linear. This difficulty is easily avoided by diluting the sample.

The sensitivity of cation separations is quite good. For alkali metal ions, we estimate a routine detection level of 5×10^{-6} M (~ 0.1 ppm for sodium), although a sensitivity of approximately 5×10^{-7} M has been obtained in special cases. For magnesium and calcium, the estimated sensitivity is 1×10^{-5} M (~ 0.5 ppm for calcium) for routine analysis, while the best ever obtained was approximately 1×10^{-6} M.

Calibration plots of peak height vs. solute ion concentration are very linear up to at least the point where the ion concentration is 25% of the molar concentration of the eluent. Using peak area and 1×10^{-3} M ethylenediammonium nitrate eluent, linear calibration curves were obtained from 6×10^{-4} M to 6×10^{-3} M calcium(II) or magnesium(II) with a correlation coefficient of 0.9989 for calcium and 0.992 for magnesium. Based on peak area we obtained a relative standard deviation of 1.5% for magnesium at 6.0×10^{-5} M (1.46 ppm) and 2.6% for calcium at 6.0×10^{-5} M (2.40 ppm). Six injections were made.

CONCLUSIONS

Cation chromatography, as outlined in this paper, is a very simple method that is capable of achieving excellent separations of metal cations. Undoubtedly, separations of various amine cations can also be obtained. The fact that no suppressor column is used simplifies the method and also allows the solution pH to be controlled throughout the system. Preliminary results indicate that cadmium(II), copper(II), nickel(II) and other metal ions that would react with a hydroxide form suppressor column can be eluted and perhaps separated in the present chromatographic system.

Analysis of alkali metals by cation chromatography rivals atomic spectroscopy in speed and convenience. Chromatography has the advantage that the ammonium ion can be determined simultaneously. Cation chromatography is promising as a routine method for water hardness analysis; it gives both magnesium and calcium hardness and not just the total hardness.

REFERENCES

1. Small, H.; Stevens, T. S.; Bauman, W. C. Anal. Chem. 1975, 47, 1801.
2. Gjerde, D. T.; Fritz, J. S.; Schmuckler, G. J. Chromatogr. 1979, 186, 509.
3. Gjerde, D. T.; Schmuckler, G.; Fritz, J. S. J. Chromatogr. 1980, 187, 35.
4. Small, H. J. Inorg. Nucl. Chem. 1961, 18, 232.
5. Dionex Corp. Sunnyvale, CA, U.S.A., January 1979, Applications Note 17.

GENERAL CONCLUSIONS

In this work, several ion-exchange resins are synthesized and characterized. Many of the low-capacity resins are used in the chromatographic separation and automatic detection of ions. Perhaps one of the most significant accomplishments of this work is the demonstration of how conductivity may be used as a chromatographic detector if the separating resin and eluent are carefully chosen. The response of conductivity detectors to ions in solution is a universal characteristic, and previously it was difficult to use them as detectors in ion-exchange chromatography. Conductivity detectors are attractive because they are sensitive and rugged.

FUTURE WORK

Although the analytical methods of anion chromatography and cation chromatography are already commercially available from Wescan Instruments, Inc. (Santa Clara, CA) the technique could be improved.

The ion-exchange resin could be improved by using smaller, more uniform particles. Preliminary results (4) show that a column of XAD-1 anion exchanger ground and sized to 20-25 μm has at least double the number of theoretical plates as a column of 44-58 μm (250-325 mesh) XAD-1 anion exchanger. XAD-1 is not available as small spherical beads, but other poly (styrene-divinylbenzene) resins are available, and these could be tried as substrates for low-capacity resins.

Different eluents could also be investigated. Work by Book and Fritz (5) shows that a dilute solution of potassium 1, 3, 5 benzenetricarboxylate is a good eluent for the separation of benzenesulfonates and other normally late eluting ions. Other work (4) shows benzoic acid is a better eluent than potassium benzoate for separating earlier eluting anions. A particularly good separation of acetate, propionate, formate, fluoride, phosphate, chloride and nitrate was achieved with 1.0×10^{-3} M benzoic acid, pH = 3.70 on XAD-1 0.023 mequiv./g.

It should be possible to design a more sensitive detector. The Wescan instrument used in this work uses an alternating peak-to-peak voltage of 20 volts at 10,000 Hz. The values are fixed and it was not possible to ascertain if these are the optimum conditions. Also the cell constant of this detector is 30 cm^{-1} . Better sensitivity could probably be achieved with a lower cell constant; however, it is possible to overload the electronics if the cell constant is too low.

Work by Roberts et al. (6) shows that it should be possible to use a small ion-exchange concentrating column in place of the sample loop. When the sample injection valve is in the load position the sample would be pumped through the concentrator column, and sample ions are taken up. Switching the injection valve to "inject" places the concentrator column in the eluent stream, and the sample ions would be eluted on to the separator column. When 10 mL samples are taken instead of the usual 0.1 mL, it should be possible to determine as little as 1 ppb chloride and 2 ppb sulfate.

The advantages of programming the strength of the eluent are obvious. Ion chromatographic methods have a background signal so it is difficult to keep the baseline straight when the strength of the eluent is changed. One possible way to avoid this difficulty is to use a differential detector in which the column effluent conductivity

would be matched with a reference cell conductivity. The eluent stream would be split before reaching the pump. Half of the eluent would be used to separate the sample anions, and the other half would be sent through the reference cell. Another possible way to program the strength of the eluent is to start with potassium benzoate, a weak eluent, and finish with potassium phthalate, a much stronger eluent. The eluent concentrations could then be adjusted so that the specific conductances are equal, and therefore, the background conductivity would not change as the eluent is changed from one to the other. The potassium benzoate concentration would be approximately double the potassium phthalate concentration.

It may be possible to program the retention times of ions in a different way. The apparent capacity of a weak-base anion exchanger changes with eluent pH. When the eluent pH is low enough, amine functional groups become protonated and become able to form an ion-pair with anions. As the eluent pH becomes more basic the weak-base ion-exchange groups become deprotonated and are no longer able to form ion-pairs. The effective ion-exchange capacity would be lowered, and sample ions would elute faster from the separating column.

The key to acceptance of any analytical method is the demonstration of applicability of that analytical method

to real samples. Many analyses of real samples have already been shown in this dissertation. Other possible applications include the analysis of chloride and sulfate in steam condensate, the analysis of magnesium and calcium in brine and the analysis of perchlorate in animal feed. When cation chromatography is extended to include some of the transition metals, simplified methods of analysis may be developed for them. Of course, applications of anion and cation chromatography are only limited by one's imagination.

An ideal analytical method does not need calibration curves. Equations similar to those developed in Section VI indicate that a response factor may be calculated for each sample ion using the difference between the equivalent conductances between the eluent ions and sample ions. A conductivity detector is an electronically calibrated instrument. The peak area of sample ion response can be directly related to sample ion concentration through the use of appropriate equations.

Gold and Calmon (7) point out one of the problems that remain to be solved in ion exchange today, namely, the high technical supervision needed in industrial and preparative ion-exchange separations. If a small portion of the effluent from a preparative column is diluted 100 or 1000 fold and then sent through a conductivity cell, it may

be possible to monitor easily the progress of the separation. If a detector of low enough sensitivity is used, it may be possible to monitor the column effluent directly with no dilution.

GENERAL REFERENCES

1. Fritz, J. S.; Story, J. N. J. Chromatogr. 1974, 90, 267.
2. Fritz, J. S.; Story, J. N. Anal. Chem. 1974, 46, 825.
3. Small, H.; Stevens, T. S.; Bauman, W. C. Anal. Chem. 1975, 47, 1801.
4. Barron, R. E.; Gjerde, D. T.; Fritz, J. S., unpublished work.
5. Bock, D. E.; Fritz, J. S., unpublished work.
6. Roberts, K; Gjerde, D. T.; Fritz, J. S., unpublished work.
7. Gold, H.; Calmon, C. in "Recent Advances in Separation Techniques-II"; Norman, N. L. Ed.; the American Institute of Chemical Engineering: New York, 1980; p 60.

ACKNOWLEDGMENTS

The author wishes to express his sincere thanks to Dr. James S. Fritz and Dr. Gabriella Schmuckler for their advice, encouragement, and helpful discussions in this work. Thanks also are extended Wang-Nang Wang, Richard J. Phillip, Robert E. Barron, and Robert Hofer for their helpful discussions. The understanding of Helen and my family is especially appreciated.